

High PSRR, low drop linear regulator IC

Datasheet - production data

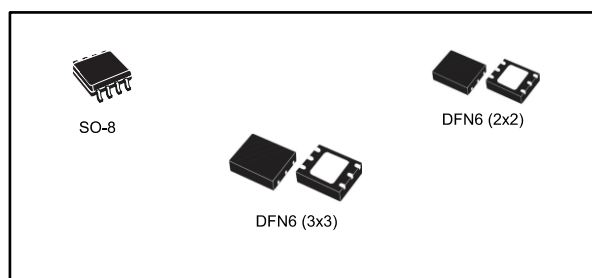

Features

- Input voltage from 2.5 V to 18 V
- 20 V AMR
- Any fixed output voltages, from 1.2 V to 12 V in 100 mV steps (from 1.2 V to 6.6 V in 50 mV steps) available on request
- Adjustable version from 1.18 V to $V_{IN} - V_{DROP(MAX)}$
- Guaranteed output current 1.2 A
- Typical dropout 350 mV@1.2 A
- Undervoltage lockout
- Enable function
- Internal thermal, current and power limitation
- High PSRR: 87 dB @ 120 Hz, 75 dB @ 1 kHz
- Operating temperature range: -40 °C to 125 °C
- Packages SO-8 batwing plastic micropackage, DFN6 (3x3) and DFN6 (2x2)

Applications

- Consumer
- Industrial
- SMPS
- Point-of-load
- DC-DC post-regulation

Description

The LDL212 provides 1.2 A of maximum current from an input voltage range from 2.5 V to 18 V, with a typical dropout voltage of 350 mV @ 1.2 A. The high power supply rejection ratio of 87 dB at 120 Hz, and more than 40 dB at 100 kHz, makes the LDL212 suitable for direct regulation in SMPS and secondary linear regulation in DC-DC converters. The LDL212 goes to shutdown mode due to the enable logic control function, reducing the total current consumption. The device also includes the current limit, SOA and thermal protections.

Contents

1	Block diagram.....	3
2	Pin configuration	4
3	Typical application	5
4	Maximum ratings	6
5	Electrical characteristics	7
6	Typical performance characteristics	9
7	Package information	15
	7.1 DFN6 (3x3) package information	15
	7.2 DFN6 (3x3) packing information.....	17
	7.3 DFN6 (2x2) package information	19
	7.4 DFN6 (2x2) packing information.....	22
	7.5 SO8-batwing package information	23
	7.6 SO8-batwing packing information	25
8	Ordering information.....	26
9	Revision history	27

1 Block diagram

Figure 1: Block diagram (fixed)

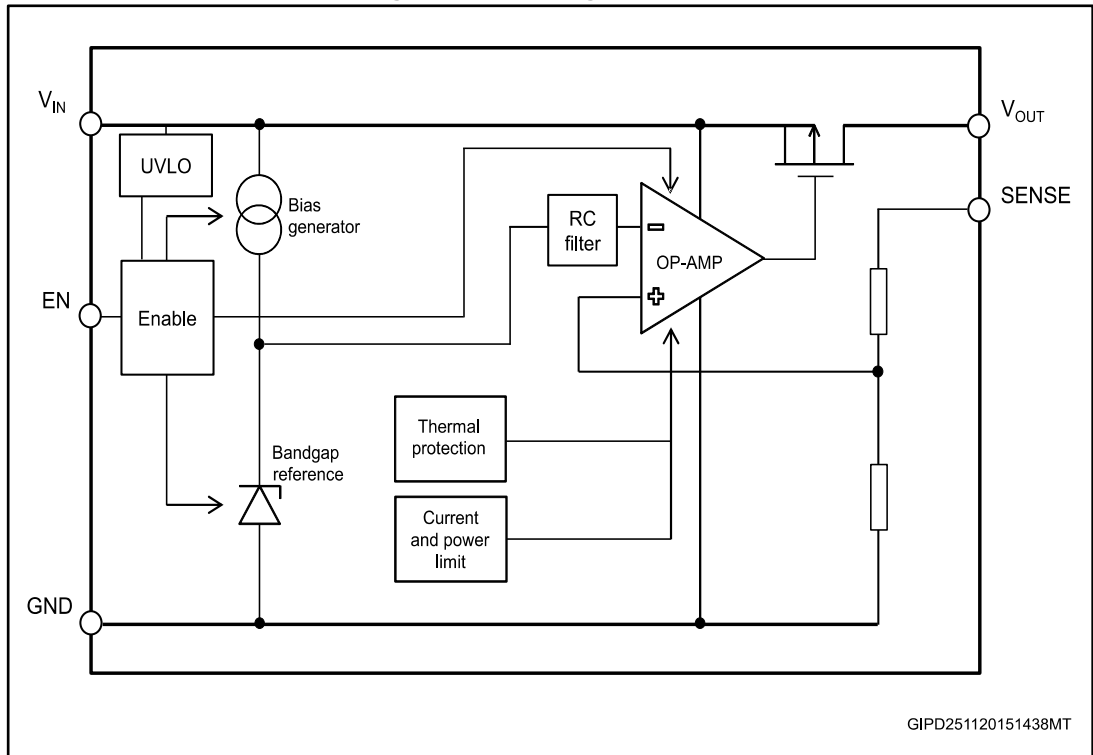
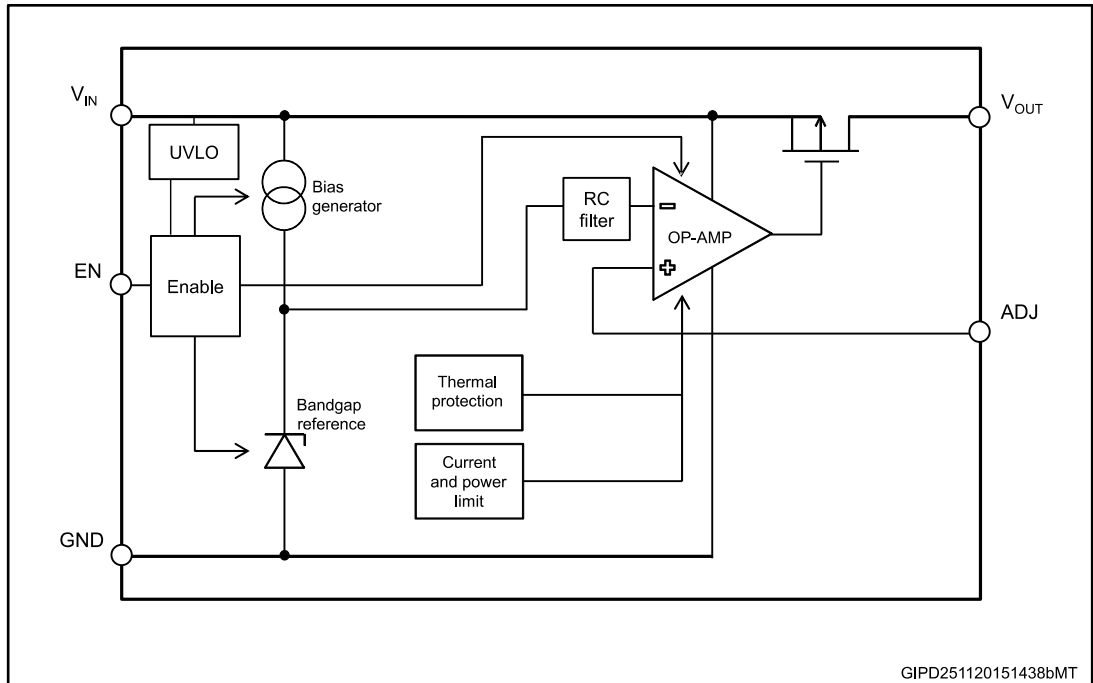

Figure 2: Block diagram (adjustable)



2 Pin configuration

Figure 3: Pin configuration (top view)

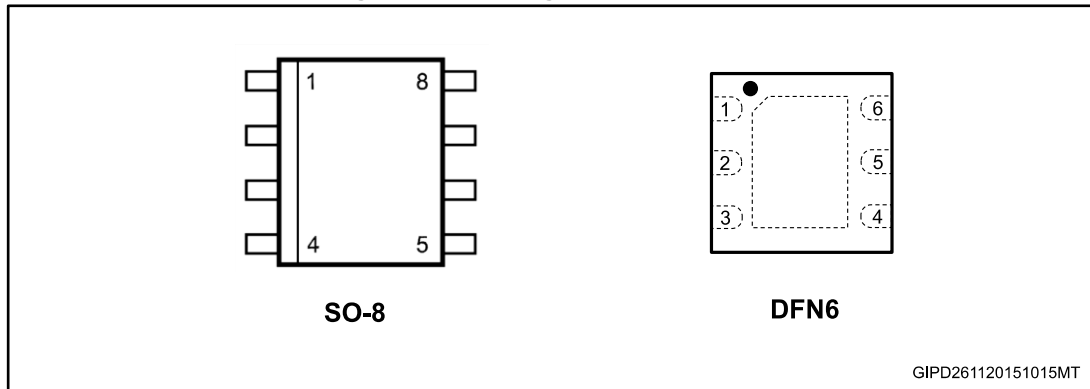

Table 1: Pin description

Pin name	Pin number (SO-8)	Pin number (DFN6)	Description
V _{IN}	4	4	Input voltage
V _{OUT}	1	3	Output voltage
GND	2, 3, 6, 7	1	Ground
ADJ/sense	8	2	Feedback pin for adjustable version / V _{OUT} sense ⁽¹⁾ on fixed version
EN	5	6	Enable pin. The device is in off-state when this pin is pulled low
NC	-	5	Not connected

Notes:

⁽¹⁾ The sense pin on the fixed version must be connected to V_{OUT} for proper operation.

3 Typical application

Figure 4: Typical application circuit (adjustable version)

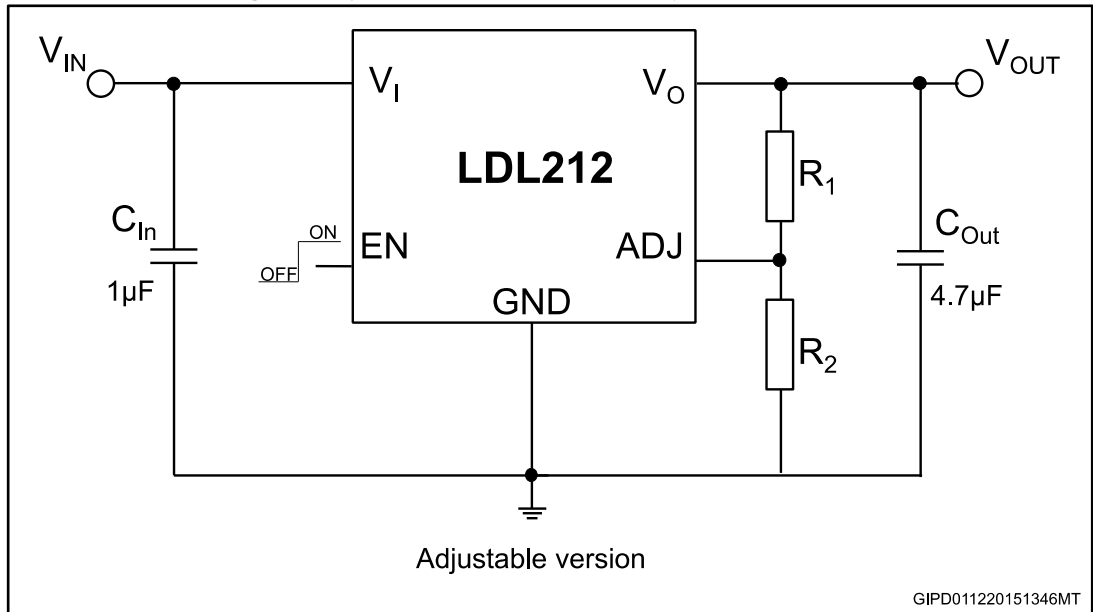
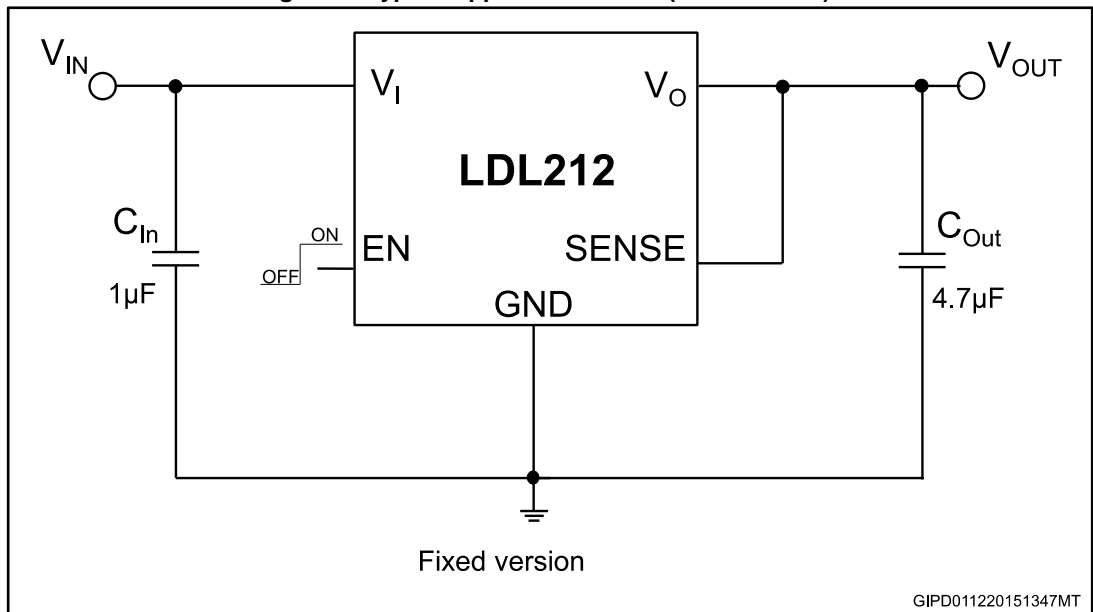

Figure 5: Typical application circuit (fixed version)



R1 and R2 are calculated according to the following formula: $R_1 = R_2 \times (V_{OUT}/V_{ADJ} - 1)$. The output voltage of the adjustable version can be set from 1.18 V to $V_{IN} - V_{DROP(MAX)}$, where $V_{DROP(MAX)}$ is the maximum dropout voltage, as defined in [Table 4: "Electrical characteristics"](#).

4 Maximum ratings

Table 2: Absolute maximum ratings

Symbol	Parameter	Value	Unit
V_{IN}	DC input voltage	- 0.3 to 20	V
V_{OUT}	DC output voltage	- 0.3 to $V_{IN} + 0.3$	V
V_{EN}	Enable input voltage	- 0.3 to $V_{IN} + 0.3$	V
V_{SENSE}	Output sense pin voltage	- 0.3 to $V_{IN} + 0.3$	V
V_{ADJ}	ADJ pin voltage	- 0.3 to 2	V
I_{OUT}	Output current	Internally limited	mA
P_D	Power dissipation	Internally limited	mW
T_{STG}	Storage temperature range	- 55 to 150	°C
T_{OP}	Operating junction temperature range	- 40 to 125	°C



Absolute maximum ratings are those values beyond which damage to the device may occur. Functional operation under these conditions is not implied.

Table 3: Thermal data

Symbol	Parameter	Value	Unit
SO-8 batwing plastic micropackage	Thermal resistance junction-to-case	20	°C/W
	Thermal resistance junction-to-ambient	55	
DFN6 (2x2)	Thermal resistance junction-to-case	15	
	Thermal resistance junction-to-ambient	65	
DFN6 (3x3)	Thermal resistance junction-to-case	10	
	Thermal resistance junction-to-ambient	55	

5 Electrical characteristics

$T_J = 25\text{ °C}$, $V_{IN} = V_{OUT(NOM)} + 1\text{ V}$, $C_{IN} = 1\text{ }\mu\text{F}$, $C_{OUT} = 4.7\text{ }\mu\text{F}$, $I_{OUT} = 10\text{ mA}$, $V_{EN} = V_{IN}$, unless otherwise specified. ^a

Table 4: Electrical characteristics

Symbol	Parameter	Test conditions	Min.	Typ.	Max.	Unit
V_{IN}	Operating input voltage		2.5		18	V
V_{UVLO}	Turn-on threshold			2.3	2.4	V
	Hysteresis			200		mV
V_{OUT}	V_{OUT} accuracy	$I_{OUT} = 10\text{ mA}$	-2		2	%
		$T_J = 25\text{ °C}$				
		$I_{OUT} = 10\text{ mA}$	-3		3	%
		$-40\text{ °C} < T_J < 125\text{ °C}$				
V_{ADJ}	Adjustable pin voltage	$V_{IN} = 2.5\text{ V}$ $I_{OUT} = 10\text{ mA}$ $T_J = 25\text{ °C}$	-2	1.18	+2	V
		$V_{IN} = 2.5\text{ V}$ $I_{OUT} = 10\text{ mA}$ $-40\text{ °C} < T_J < 125\text{ °C}$	-3		+3	%
I_{ADJ}	Adjustable pin current	$V_{IN} = 2.5\text{ V}$ $I_{OUT} = 10\text{ mA}$		20		nA
ΔV_{OUT}	Line regulation	$V_{OUT} + 1\text{ V} \leq V_{IN} \leq 18\text{ V}$ $I_{OUT} = 10\text{ mA}$		0.002	0.01	%/V
ΔV_{OUT}	Load regulation	$I_{OUT} = 10\text{ mA}$ to 1.2 A		0.0001	0.0005	%/mA
V_{DROP}	Dropout voltage ⁽¹⁾	$I_{OUT} = 1.2\text{ A}$ $V_{OUT} > 3\text{ V}$ $-40\text{ °C} < T_J < 125\text{ °C}$		350	600	mV
eN	Output noise voltage	10 Hz to 100 kHz, $I_{OUT} = 100\text{ mA}$		60		$\mu\text{V}_{RMS}/V_{OUT}$
SVR	Supply voltage rejection	$V_{IN} = V_{OUT(NOM)} + 1\text{ V} \pm V_{RIPPLE}$		87		dB
		$V_{RIPPLE} = 0.5\text{ V}$, $f = 120\text{ Hz}$				
		$V_{IN} = V_{OUT(NOM)} + 1\text{ V} \pm V_{RIPPLE}$		75		
		$V_{RIPPLE} = 0.5\text{ V}$, $f = 1\text{ kHz}$				
$V_{IN} = V_{OUT(NOM)} + 1\text{ V} \pm V_{RIPPLE}$		50				
$V_{RIPPLE} = 0.5\text{ V}$, $f = 100\text{ kHz}$						
I_q	Quiescent current	$I_{OUT} = 0\text{ mA}$ to 1.2 A $-40\text{ °C} < T_J < 125\text{ °C}$		250	380	μA
		V_{IN} input current in OFF mode		0.3	1.5	

^a For $V_{OUT(NOM)} \leq 1.5\text{ V}$, $V_{IN} = 2.7\text{ V}$.

Symbol	Parameter	Test conditions	Min.	Typ.	Max.	Unit
		$V_{EN} = \text{GND}$ $V_{IN} = 18 \text{ V}$				
I_{SC}	Short-circuit current	$R_L = 0$	1.5	2		A
V_{EN}	Enable input logic low	$V_{IN} = 2.5 \text{ V to } 18 \text{ V}$ $-40 \text{ }^\circ\text{C} < T_J < 85 \text{ }^\circ\text{C}$			0.4	V
	Enable input logic high	$V_{IN} = 2.5 \text{ V to } 18 \text{ V}$ $-40 \text{ }^\circ\text{C} < T_J < 85 \text{ }^\circ\text{C}$	1.2			
I_{EN}	Enable input current			1.5		μA
		$V_{EN} = V_{IN}$, $V_{IN} = 18 \text{ V}$		16	20	
T_{ON}	Turn-on time ⁽²⁾			120		μs
T_{SHDN}	Thermal shutdown			175		$^\circ\text{C}$
	Hysteresis			25		

Notes:

⁽¹⁾ Dropout voltage is the input-to-output voltage difference at which the output voltage is 100 mV below its nominal value. This specification is not valid for output voltages below 2.2 V.

⁽²⁾ Turn-on time is the time measured between the enable input just exceeding V_{EN} high value and the output voltage just reaching 95% of its nominal value.

6 Typical performance characteristics

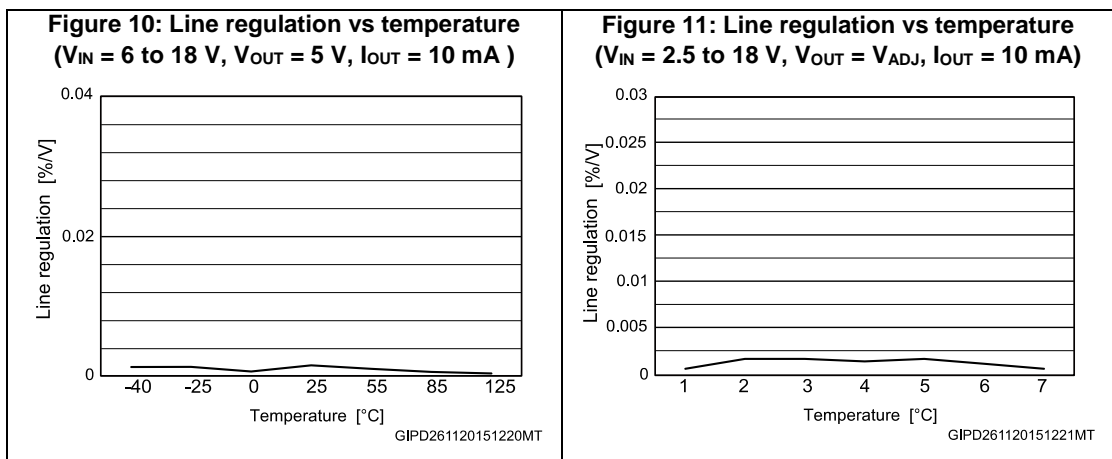
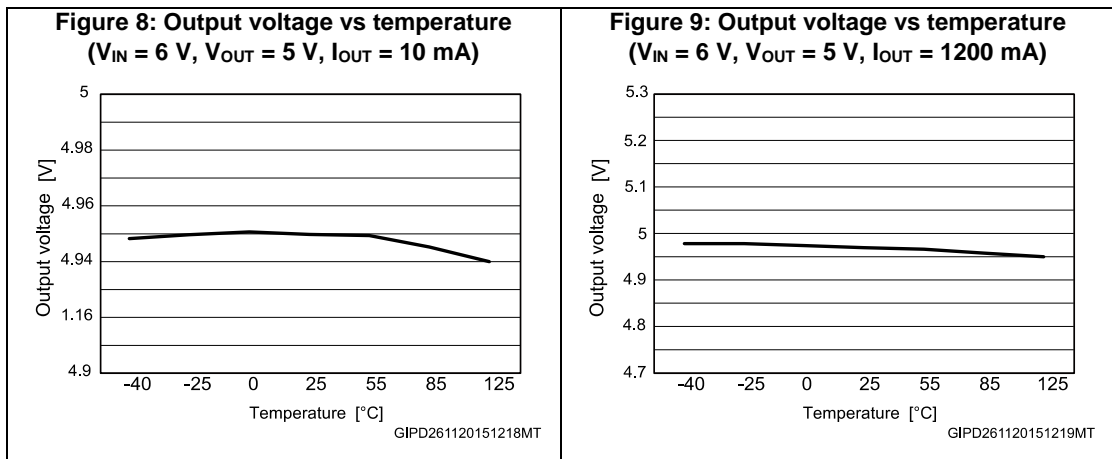
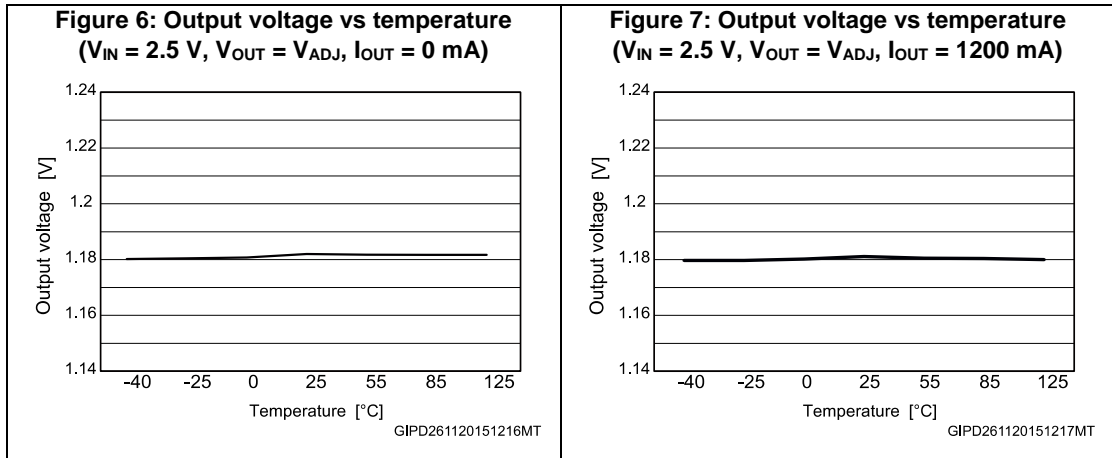

Figure 12: Load regulation vs temperature
 ($V_{IN} = 6\text{ V}$, $V_{OUT} = 5\text{ V}$, $I_{OUT} = 10\text{ to }1200\text{ mA}$)

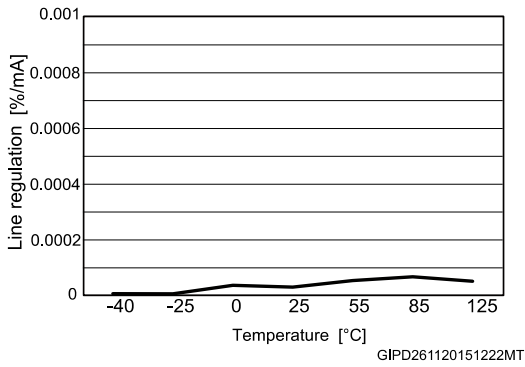

Figure 13: Load regulation vs temperature
 ($V_{IN} = 2.5\text{ V}$, $V_{OUT} = V_{ADJ}$, $I_{OUT} = 0\text{ to }1200\text{ mA}$)

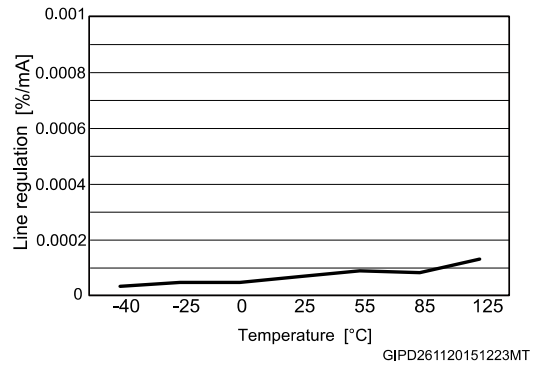

Figure 14: Enable thresholds vs temperature
 ($V_{OUT} = V_{ADJ}$)

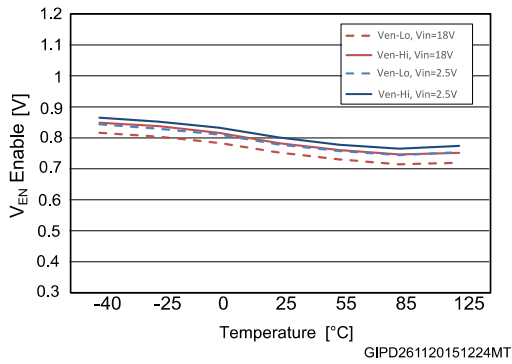

Figure 15: Enable thresholds vs temperature
 ($V_{OUT} = 5\text{ V}$)

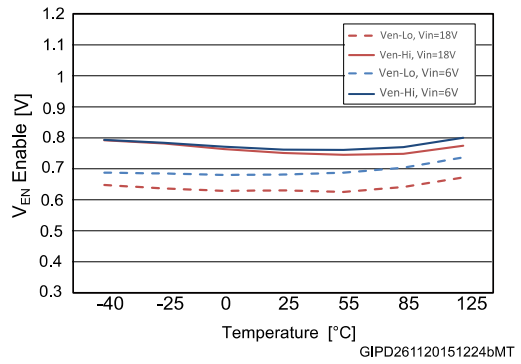

Figure 16: Dropout voltage vs temperature

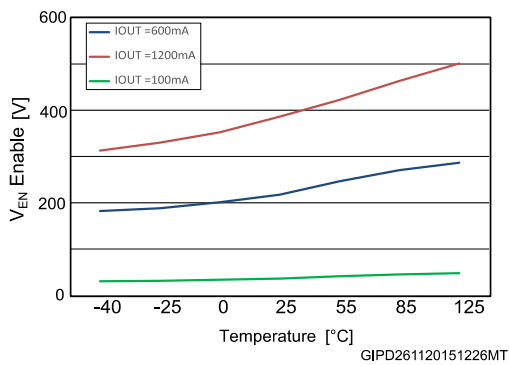

Figure 17: Quiescent current vs temperature
 ($V_{OUT} = 5\text{ V}$, $I_{OUT} = 0\text{ mA}$)

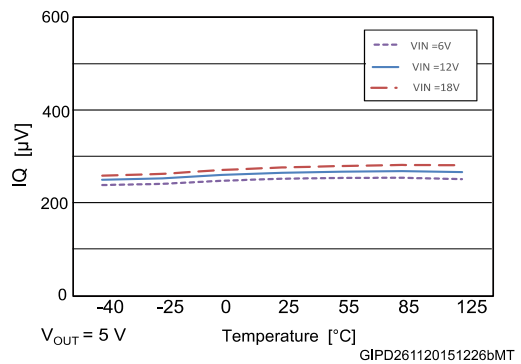

Figure 18: Quiescent current vs temperature
 ($V_{OUT} = 5\text{ V}$, $I_{OUT} = 600\text{ mA}$, 1.2 A)

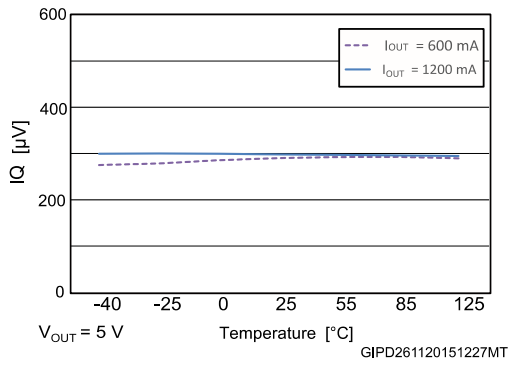

Figure 19: Quiescent current vs temperature
 ($V_{OUT} = V_{ADJ}$, $I_{OUT} = 0\text{ mA}$)

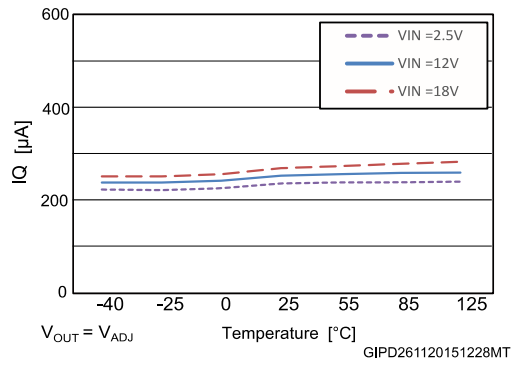

Figure 20: Quiescent current vs temperature
 ($V_{OUT} = V_{ADJ}$, $I_{OUT} = 600\text{ mA}$)

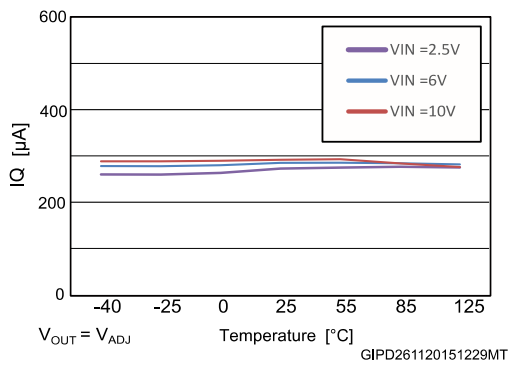

Figure 21: Quiescent current vs temperature
 ($V_{OUT} = V_{ADJ}$, $I_{OUT} = 1.2\text{ A}$)

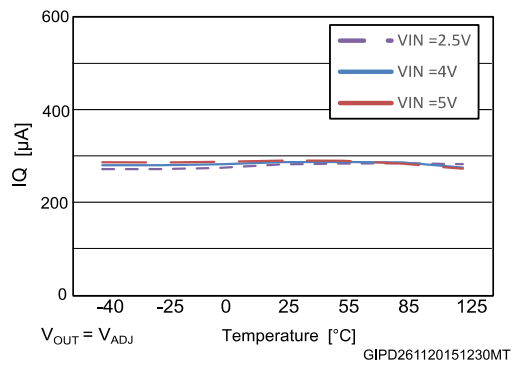

Figure 22: Off-state current vs temperature
 ($V_{OUT} = 5\text{ V}$)

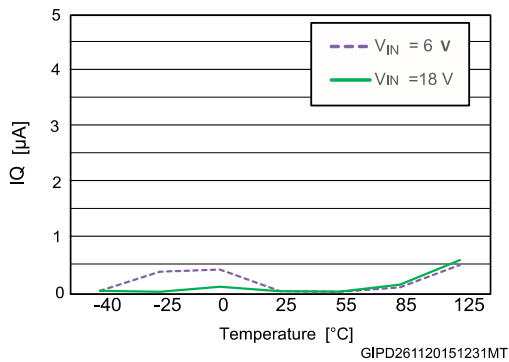

Figure 23: Off-state current vs temperature
 ($V_{OUT} = V_{ADJ}$)

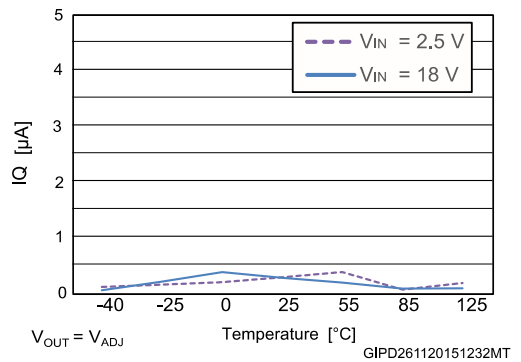
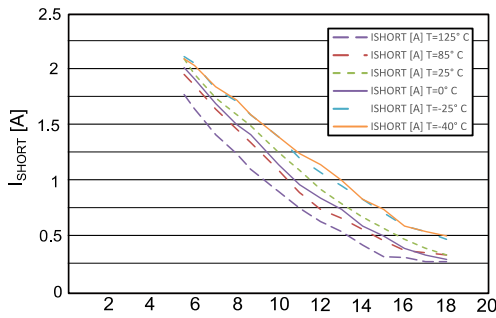
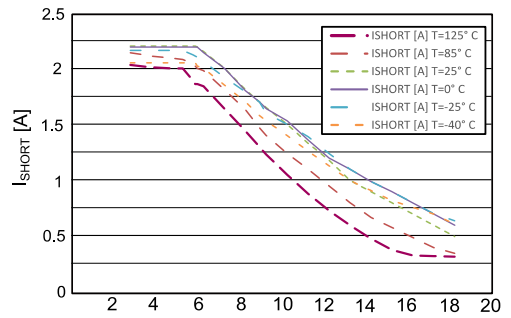

Figure 24: Short-circuit current vs dropout voltage ($V_{OUT} = 5\text{ V}$)



V_{EN} to V_{IN} , $C_{IN}=1\mu\text{F}$, $C_{OUT}=4.7\mu\text{F}$ GIPD261120151233MT

Figure 25: Short-circuit current vs dropout voltage ($V_{OUT} = V_{ADJ}$)



V_{EN} to V_{IN} , $C_{IN}=1\mu\text{F}$, $C_{OUT}=4.7\mu\text{F}$ GIPD261120151235MT

Figure 26: SVR versus frequency

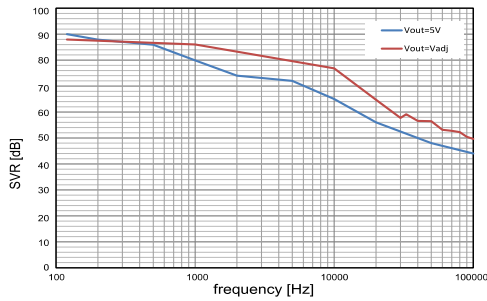

For $V_{OUT} = 5\text{ V}$, $V_{IN} = V_{EN}$ from 5.5 to 6.5V, $I_{OUT} = 10\text{ mA}$, $C_{IN} = 1\mu\text{F}$, $C_{OUT} = 4.7\mu\text{F}$
 For $V_{OUT} = V_{ADJ}$, $V_{IN} = V_{EN}$ from 2.5 to 3.5V, $I_{OUT} = 10\text{ mA}$, No C_{IN} , $C_{OUT} = 4.7\mu\text{F}$
 GIPD261120151236MT

Figure 27: Output noise spectral density ($V_O = V_{ADJ}$)

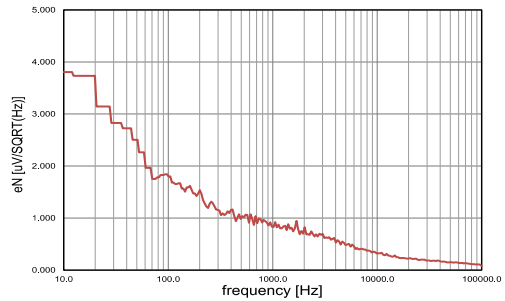

$V_{IN} = V_{EN} = 2.5\text{ V}$, $V_{OUT} = V_{ADJ}$, $I_{OUT} = 100\text{ mA}$, $C_{IN} = 1\mu\text{F}$, $C_{OUT} = 4.7\mu\text{F}$

GIPD261120151237MT

Figure 28: Output noise spectral density ($V_O = 5\text{ V}$)

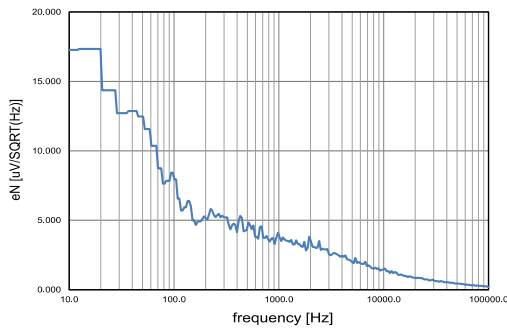

$V_{IN} = V_{EN} = 6\text{ V}$, $V_{OUT} = 5\text{ V}$, $I_{OUT} = 100\text{ mA}$, $C_{IN} = 1\mu\text{F}$, $C_{OUT} = 4.7\mu\text{F}$
 GIPD261120151238MT

Figure 29: Output noise spectral density ($V_O = 12\text{ V}$)

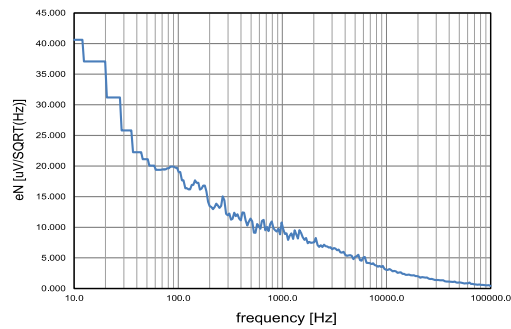

$V_{IN} = V_{EN} = 6\text{ V}$, $V_{OUT} = 5\text{ V}$, $I_{OUT} = 100\text{ mA}$, $C_{IN} = 1\mu\text{F}$, $C_{OUT} = 4.7\mu\text{F}$

GIPD261120151239MT

Figure 30: Stability plan ($V_{OUT} = 5\text{ V}$)

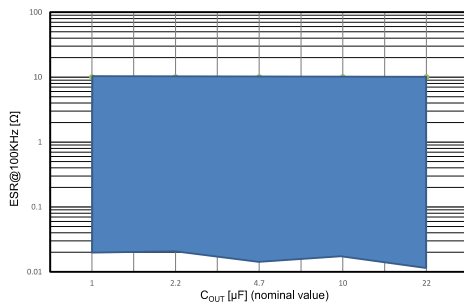

$V_{EN} = V_{IN}$ = from 6 V to 18 V, I_{OUT} = from 10 mA to 1.2 A
 (according to Max I_{OUT} vs V_{drop} characteristics), $C_{IN} = 1\ \mu\text{F}$
 GIPD301120151004MT

Figure 31: Stability plan ($V_{OUT} = V_{ADJ}$)

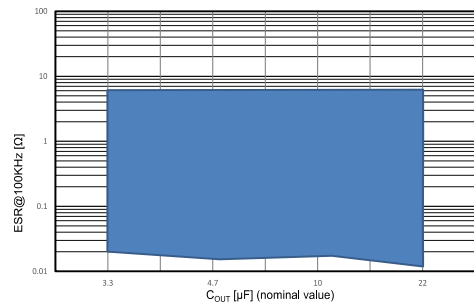

$V_{EN} = V_{IN}$ = from 2.5 V to 18 V, I_{OUT} = from 10 mA to 1.2 A
 (according to Max I_{OUT} vs V_{drop} characteristics), $C_{IN} = 1\ \mu\text{F}$
 GIPD301120151005MT

Figure 32: Startup with enable ($V_{OUT} = 5\text{ V}$)

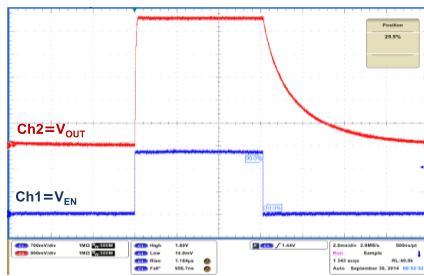

$V_{IN} = 15\text{ V}$, V_{EN} from 0 to 2 V, $I_{OUT} = 10\text{ mA}$, $C_{IN} = C_{OUT} = 1\ \mu\text{F}$, $T_{rise} = 1\ \mu\text{s}$
 GIPD301120151405MT

Figure 33: Startup with enable ($V_{OUT} = V_{ADJ}$)

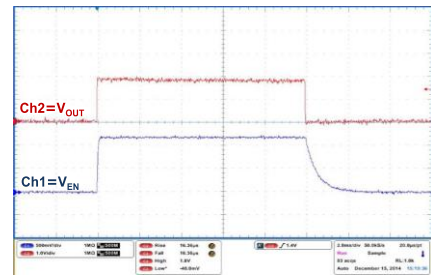

$V_{IN} = 15\text{ V}$, V_{EN} from 0 to 2 V, $I_{OUT} = 10\text{ mA}$, $C_{IN} = C_{OUT} = 1\ \mu\text{F}$, $T_{rise} = 1\ \mu\text{s}$
 GIPD301120151406MT

Figure 34: Turn-on time ($V_{OUT} = 5\text{ V}$)

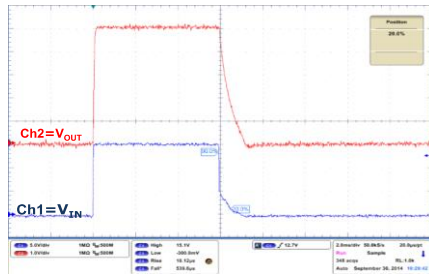

$V_{EN} = V_{IN}$ = from 0 to 15 V, $I_{OUT} = 10\text{ mA}$, $C_{OUT} = 1\ \mu\text{F}$, $T_{rise} = 10\ \mu\text{s}$
 GIPD301120151407MT

Figure 35: Turn-on time ($V_{OUT} = V_{ADJ}$)

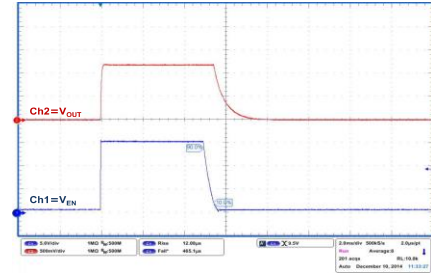

$V_{EN} = V_{IN}$ = from 0 to 15 V, $I_{OUT} = 10\text{ mA}$, $C_{IN} = 1\ \mu\text{F}$, $C_{OUT} = 4.7\ \mu\text{F}$, $T_{rise} = 10\ \mu\text{s}$
 GIPD301120151408MT

Figure 36: Line transient ($V_{OUT} = 5\text{ V}$)

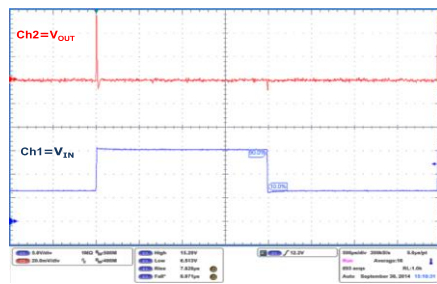

V_{IN} = from 6 to 15 V, I_{OUT} = 10 mA, C_{OUT} = 4.7 μF , t_r = 5 μs

GIPD301120151409MT

Figure 37: Line transient ($V_{OUT} = V_{ADJ}$)

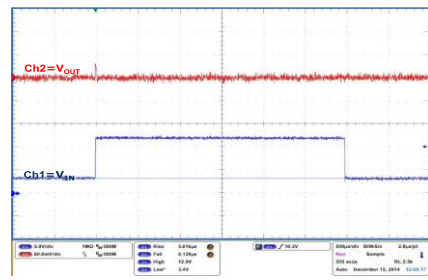

V_{IN} = from 3.5 to 15 V, I_{OUT} = 10 mA, NO C_{IN} , C_{OUT} = 4.7 μF , t_r = 5 μs

GIPD301120151410MT

Figure 38: Load transient ($V_{OUT} = 5\text{ V}$)

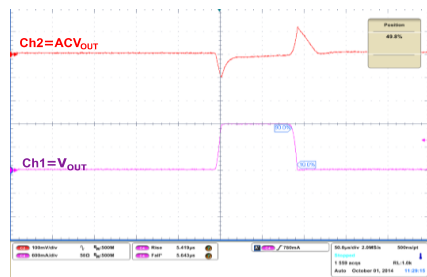

V_{EN} to V_{CC} , V_{IN} = 6 V, I_{OUT} = from 10 mA to 1.2 A, C_{IN} = 1 μF , C_{OUT} = 4.7 μF , T_{rise} = 5 μs

GIPD301120151411MT

Figure 39: Load transient ($V_{OUT} = V_{ADJ}$)

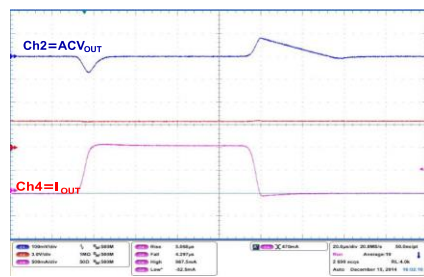

V_{EN} to V_{CC} , V_{IN} = 3.5 V, I_{OUT} = from 10 mA to 1.2 A, C_{IN} = 1 μF , C_{OUT} = 4.7 μF , T_{rise} = 5 μs

GIPD301120151412MT

7 Package information

In order to meet environmental requirements, ST offers these devices in different grades of ECOPACK® packages, depending on their level of environmental compliance. ECOPACK® specifications, grade definitions and product status are available at: www.st.com. ECOPACK® is an ST trademark.

7.1 DFN6 (3x3) package information

Figure 40: DFN6 (3x3) package outline

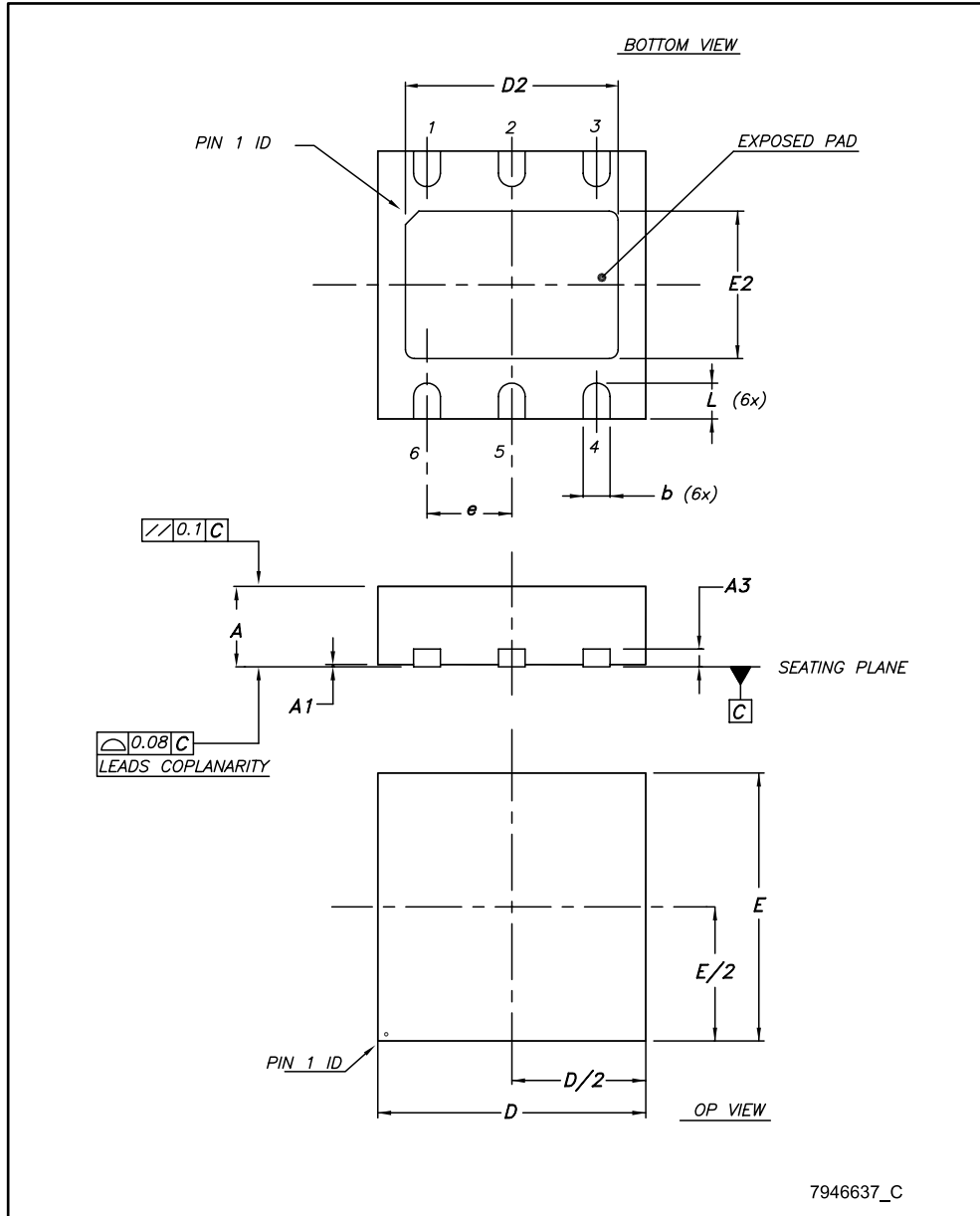
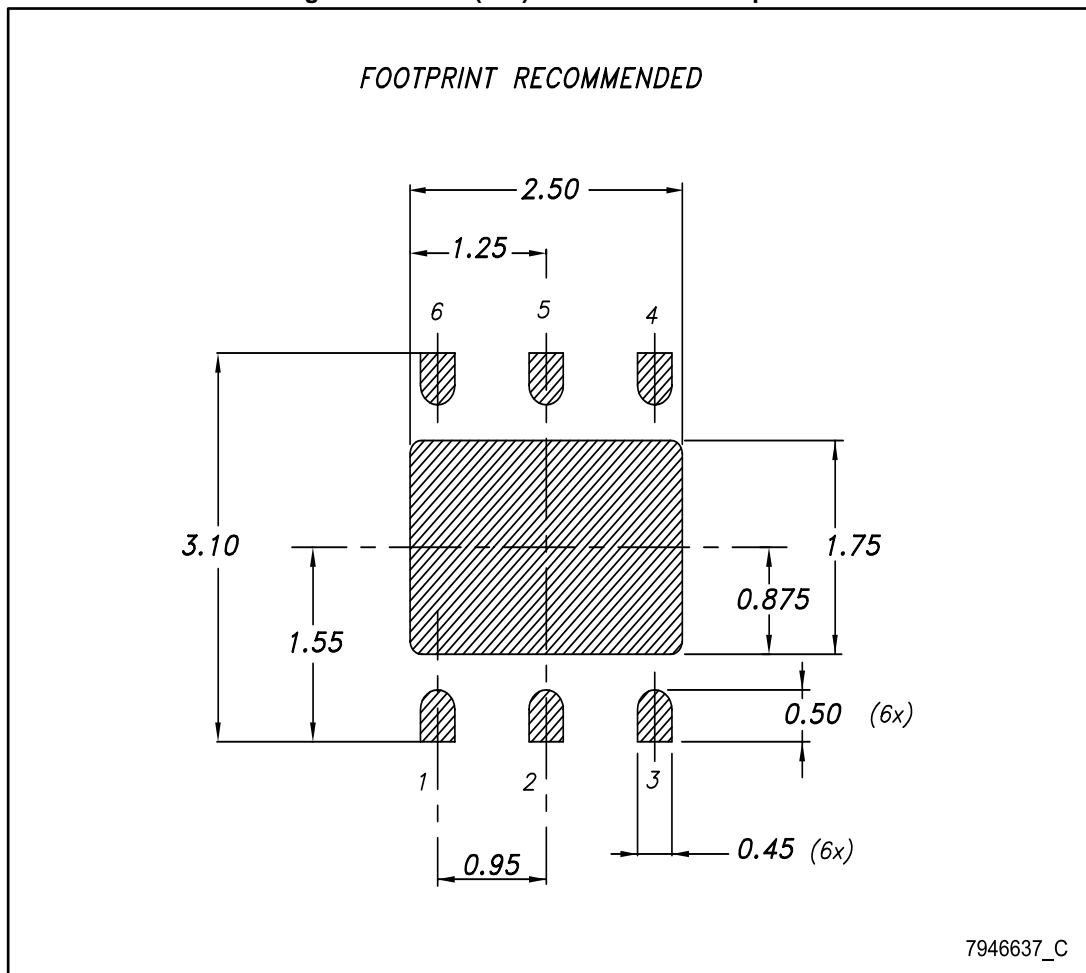

Table 5: DFN6 (3x3) mechanical data

Dim.	mm		
	Min.	Typ.	Max.
A	0.80		1
A1	0	0.02	0.05
A3		0.20	
b	0.23		0.45
D	2.90	3	3.10
D2	2.23		2.50
E	2.90	3	3.10
E2	1.50		1.75
e		0.95	
L	0.30	0.40	0.50

Figure 41: DFN6 (3x3) recommended footprint



7.2 DFN6 (3x3) packing information

Figure 42: DFN6 (3x3) tape outline

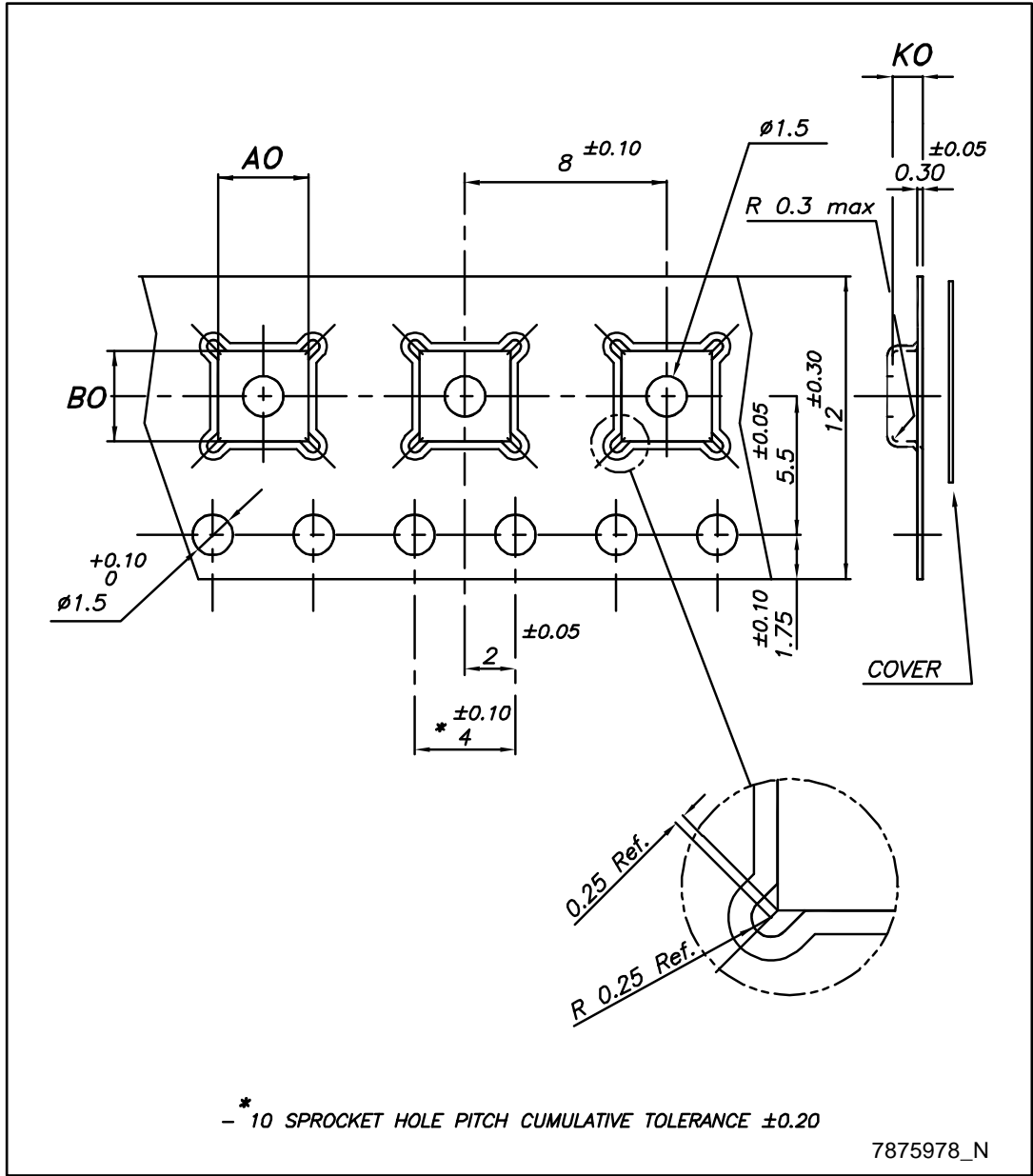
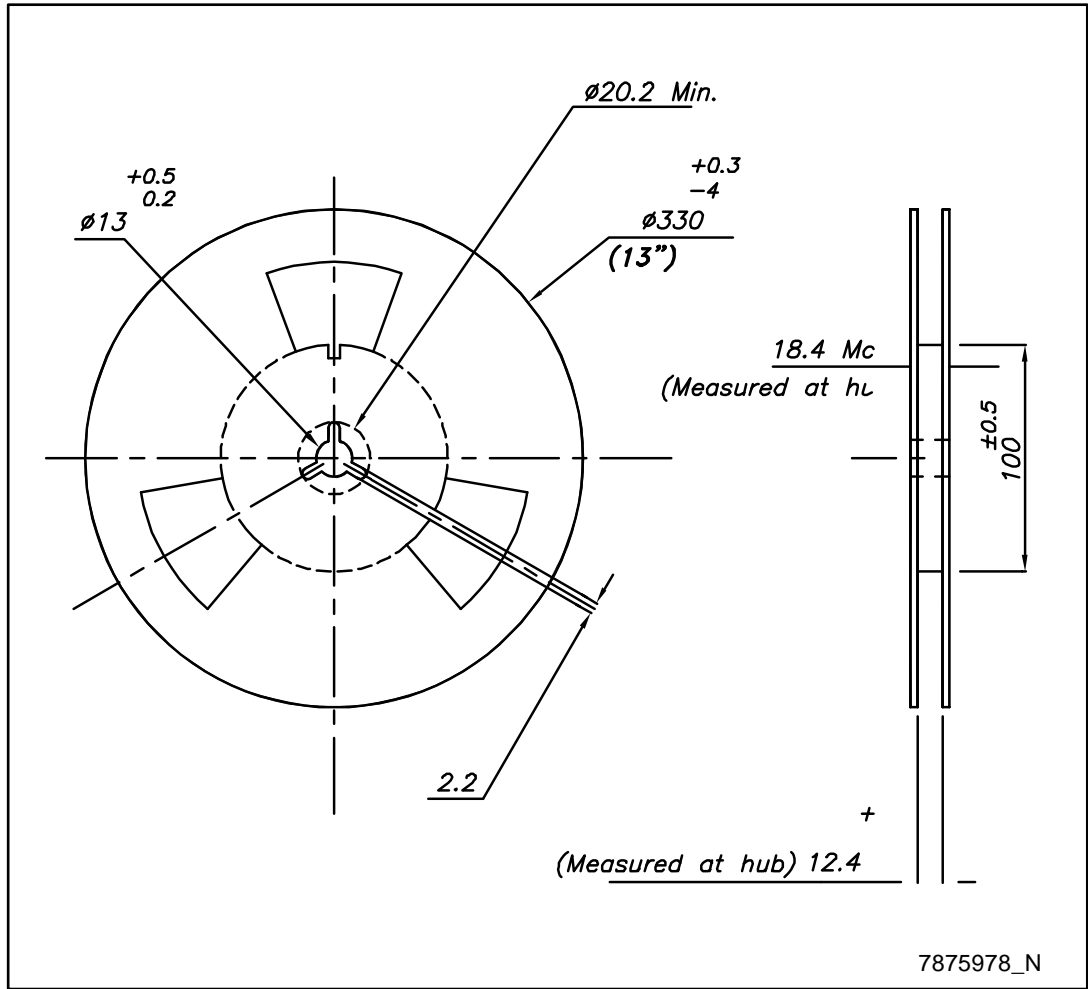

Figure 43: DFN6 (3x3) reel outline



7875978_N

Table 6: DFN6 (3x3) tape and reel mechanical data

Dim.	mm		
	Min.	Typ.	Max.
A0	3.20	3.30	3.40
B0	3.20	3.30	3.40
K0	1	1.10	1.20

7.3 DFN6 (2x2) package information

Figure 44: DFN6 (2x2) package outline

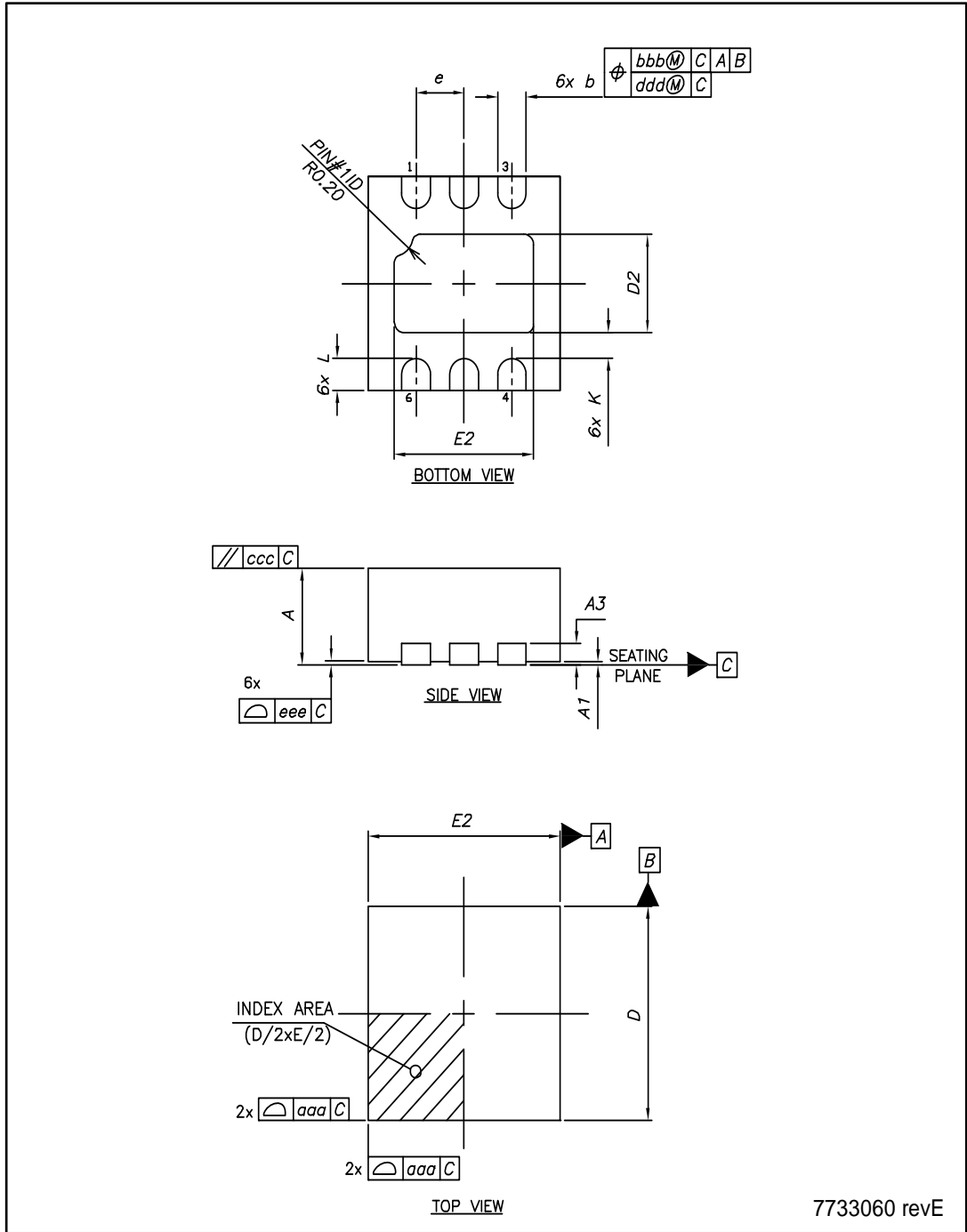
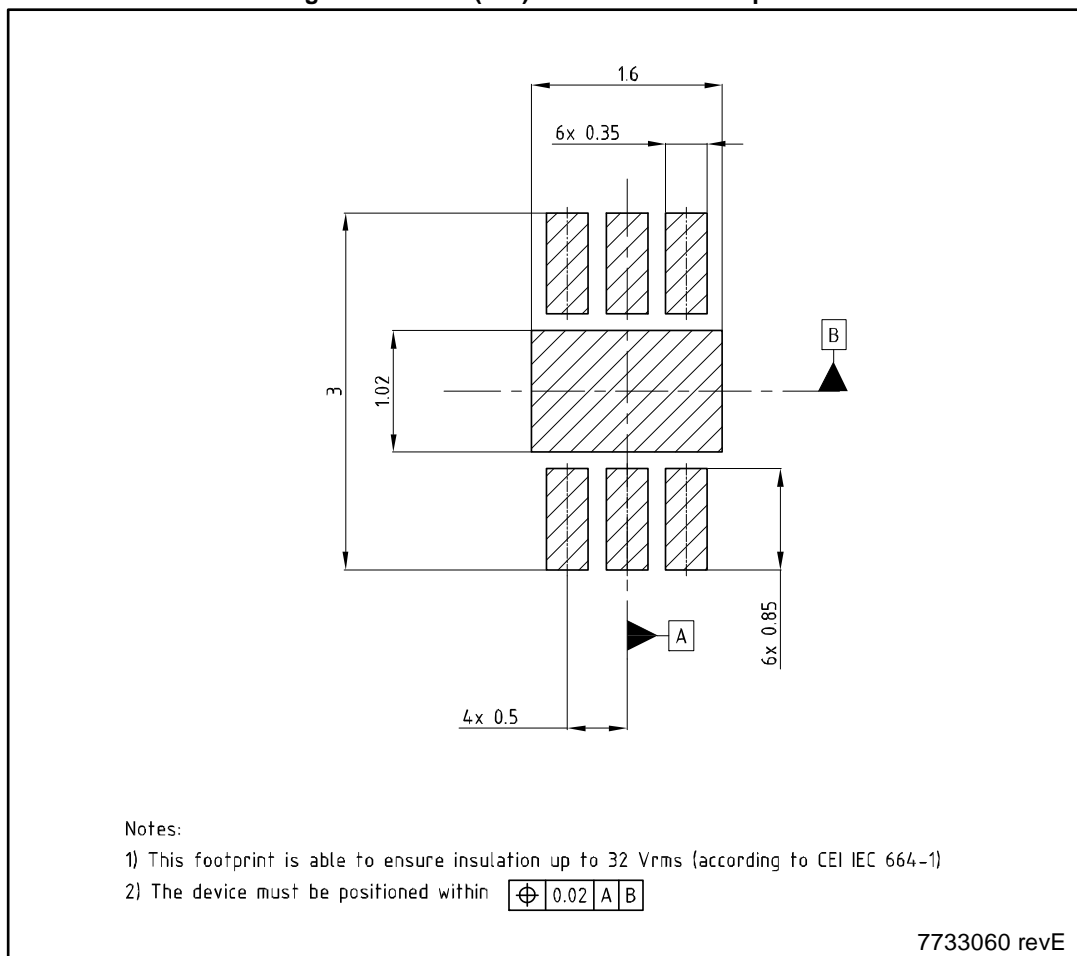

Table 7: DFN6 (2x2) mechanical data

Dim.	mm		
	Min.	Typ.	Max.
A	0.70	0.75	0.80
A1	0.00	0.02	0.05
A3	-	0.203 ref	-
b	0.25	0.30	0.35
D	-	2.00	-
E	-	2.00	-
e	-	0.50	-
D2	0.77	0.92	1.02
E2	1.30	1.45	1.55
K	0.15	-	-
L	0.20	0.30	0.40
aaa	-	0.05	-
bbb	-	0.10	-
ccc	-	0.10	-
ddd	-	0.05	-
eee	-	0.08	-

Figure 45: DFN6 (2x2) recommended footprint



7.4 DFN6 (2x2) packing information

Figure 46: DFN6 (2x2) reel outline

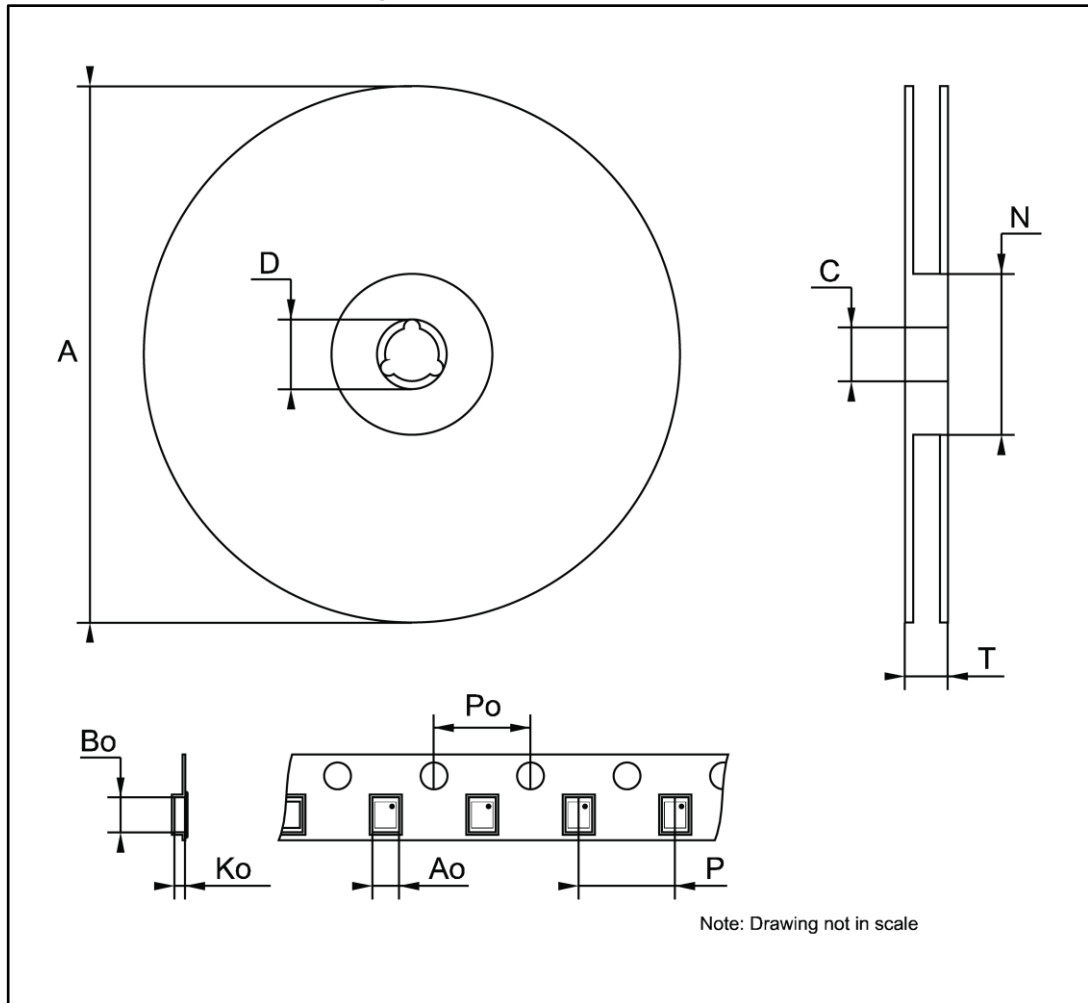

Table 8: DFN6 (2x2) tape and reel mechanical data

Dim.	mm		
	Min.	Typ.	Max.
A			180
C	12.8		13.2
D	20.2		
N	60		
T			14.4
A0		2.4	
B0		2.4	
K0		1.3	
P0		4	
P		4	

7.5 SO8-batwing package information

Figure 47: SO-8 batwing package outline

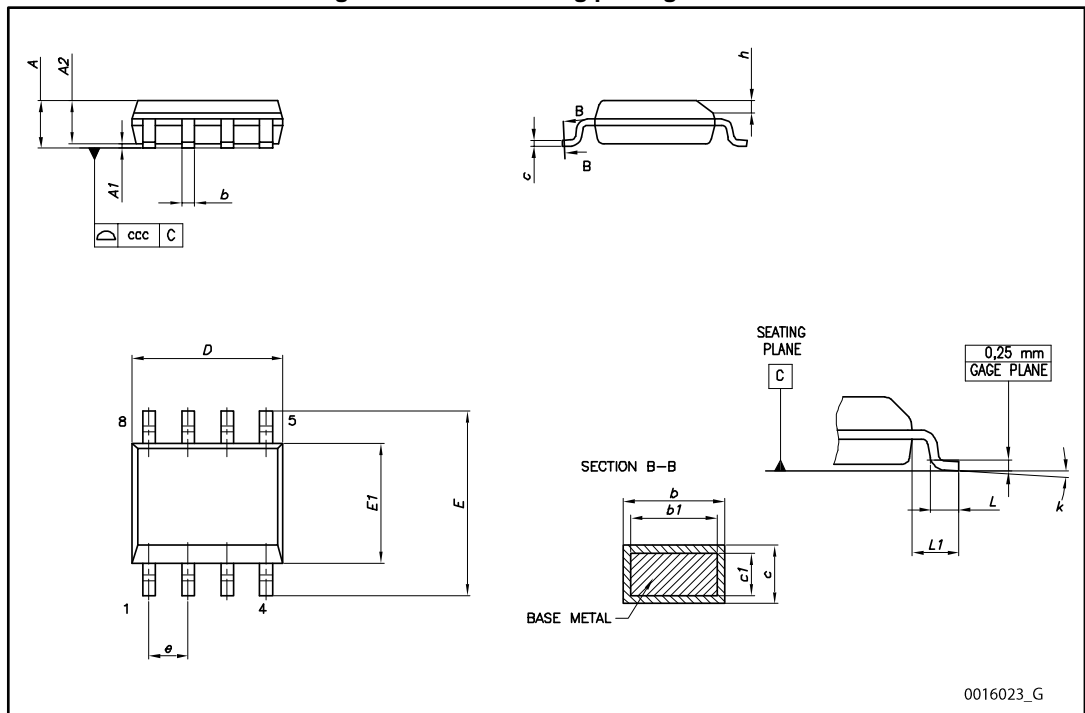
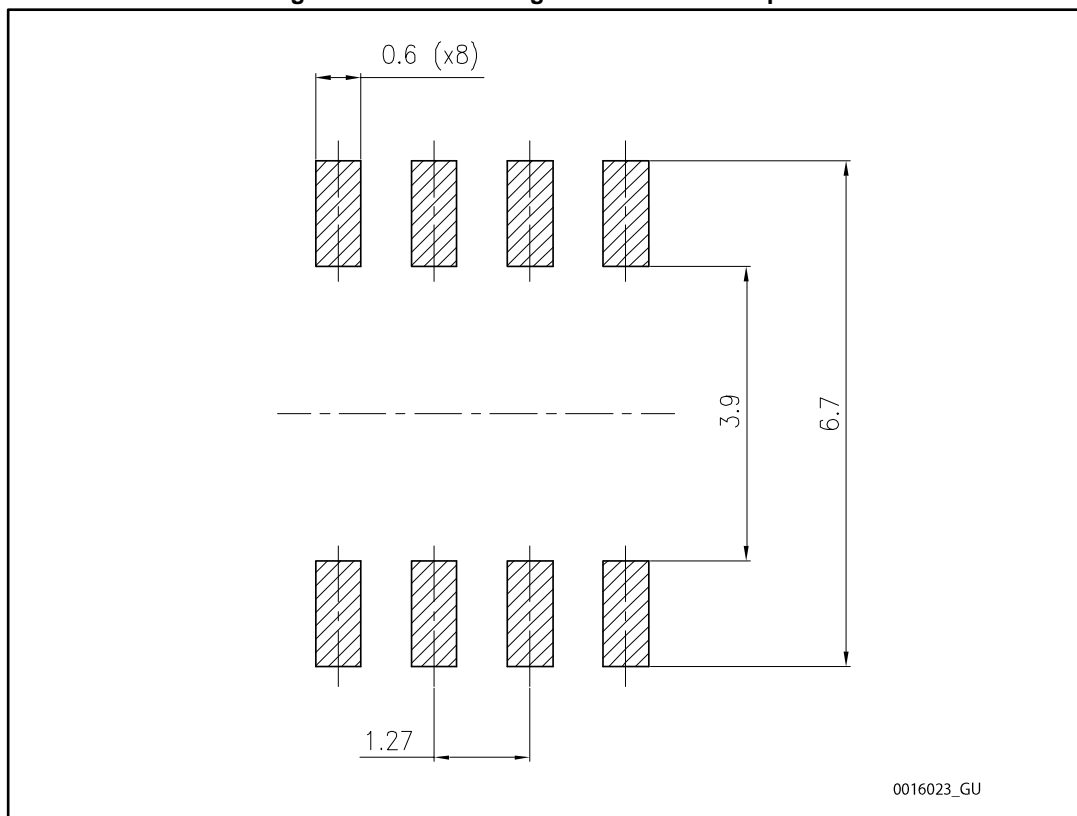

Table 9: SO-8 batwing mechanical data

Dim.	mm		
	Min.	Typ.	Max.
A			1.75
A1	0.10		0.25
A2	1.25		
b	0.31		0.51
b1	0.28		0.48
c	0.10		0.25
c1	0.10		0.23
D	4.80	4.90	5.00
E	5.80	6.00	6.20
E1	3.80	3.90	4.00
e		1.27	
h	0.25		0.50
L	0.40		1.27
L1		1.04	
L2		0.25	
k	0°		8°
ccc			0.10

Figure 48: SO-8 batwing recommended footprint



7.6 SO8-batwing packing information

Figure 49: SO8-batwing tape and reel outline

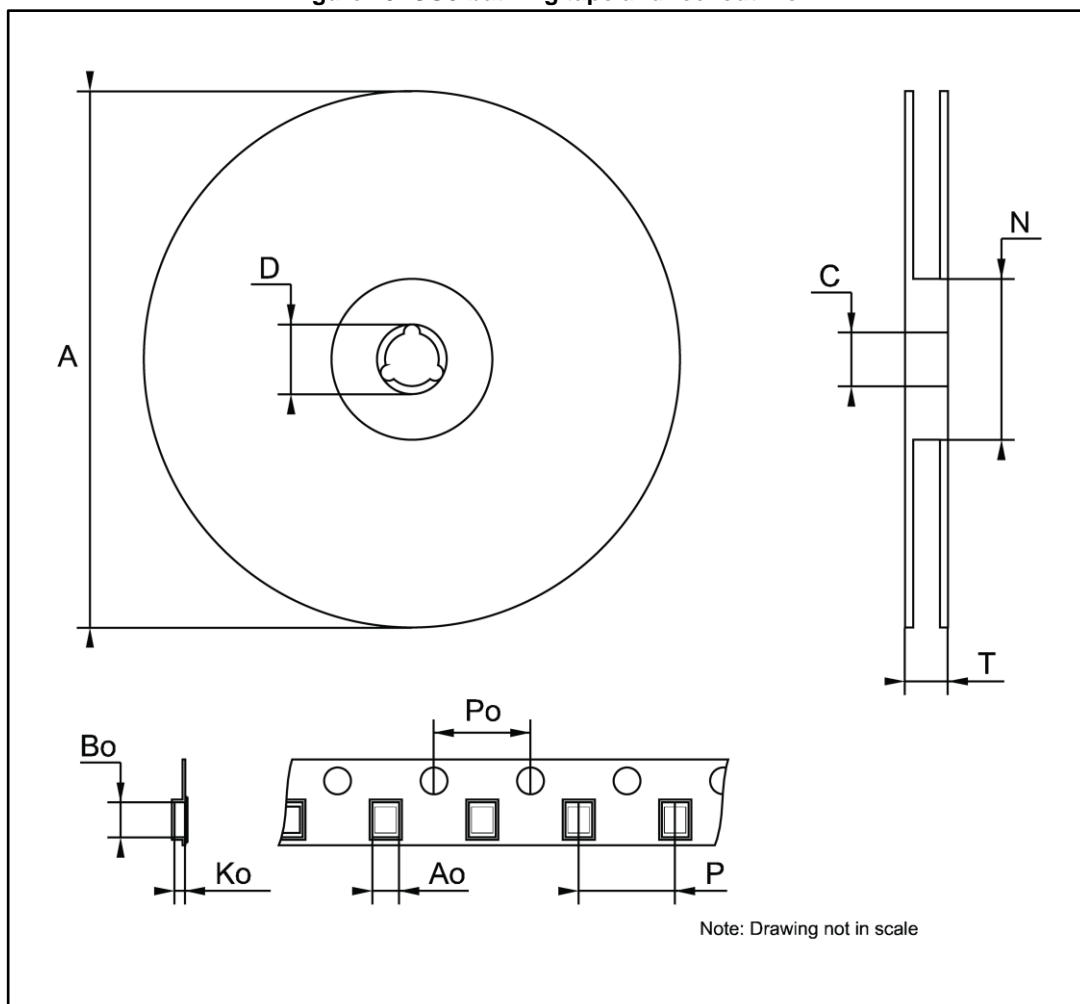

Table 10: SO8-batwing mechanical data

Dim.	mm		
	Min.	Typ.	Max.
A			330
C	12.8		13.2
D	20.2		
N	60		
T			22.4
A0	8.1		8.5
B0	5.5		5.9
K0	2.1		2.3
P0	3.9		4.1
P	7.9		8.1

8 Ordering information

Table 11: Order code

DFN6 (3x3)	DFN6 (2x2)	SO-8 batwing plastic micropackage	Output voltage (V)
LDL212PU12R			1.2
LDL212PU15R			1.5
LDL212PU18R			1.8
LDL212PU25R			2.5
LDL212PU30R			3
	LDL212D33R		3.3
LDL212PU50R			5
LDL212PUR	LDL212PVR	LDL212DR	Adjustable

9 Revision history

Table 12: Document revision history

Date	Revision	Changes
02-Mar-2016	1	Initial release.
19-Sep-2016	2	Updated <i>Table 3: "Thermal data"</i> and <i>Section 5: "Electrical characteristics"</i> . Minor text changes.

IMPORTANT NOTICE – PLEASE READ CAREFULLY

STMicroelectronics NV and its subsidiaries ("ST") reserve the right to make changes, corrections, enhancements, modifications, and improvements to ST products and/or to this document at any time without notice. Purchasers should obtain the latest relevant information on ST products before placing orders. ST products are sold pursuant to ST's terms and conditions of sale in place at the time of order acknowledgement.

Purchasers are solely responsible for the choice, selection, and use of ST products and ST assumes no liability for application assistance or the design of Purchasers' products.

No license, express or implied, to any intellectual property right is granted by ST herein.

Resale of ST products with provisions different from the information set forth herein shall void any warranty granted by ST for such product.

ST and the ST logo are trademarks of ST. All other product or service names are the property of their respective owners.

Information in this document supersedes and replaces information previously supplied in any prior versions of this document.

© 2016 STMicroelectronics – All rights reserved

Mouser Electronics

Authorized Distributor

Click to View Pricing, Inventory, Delivery & Lifecycle Information:

[STMicroelectronics:](#)

[LDL212PUR](#) [LDL212PVR](#) [LDL212DTR](#) [LDL212PU50R](#)