

FEATURES

- 1 pC charge injection
- ± 0.01 nA maximum at 25°C leakage currents
- 85 Ω on resistance
- Rail-to-rail switching operation
- Fast switching times
- 16-lead TSSOP
- Typical power consumption: ≤ 11 nW
- TTL-/CMOS-compatible inputs
- V_{SS} to V_{DD} analog signal range
 - ± 2.7 V to ± 5.5 V dual supply operation
 - 2.7 V to 5.5 V single-supply operation
- Fully specified at ± 5 V, 3 V, and 5 V

ENHANCED PRODUCT FEATURES

- Supports defense and aerospace applications (AQEC standard)
- Military temperature range: -55°C to $+125^{\circ}\text{C}$
- Controlled manufacturing baseline
- 1 assembly/test site
- 1 fabrication site
- Enhanced product change notification
- Qualification data available on request

APPLICATIONS

- Automatic test equipment
- Data acquisition systems
- Battery-powered systems
- Communications systems
- Sample-and-hold systems
- Audio signal routing
- Relay replacement
- Avionics

GENERAL DESCRIPTION

The **ADG613-EP** is a monolithic CMOS device containing four independently selectable switches. This switch offers ultralow charge injection of 1 pC over the full input signal range and typical leakage currents of 0.01 nA at 25°C.

The device is fully specified for ± 5 V, 5 V, and 3 V supplies. It contains four independent single-pole, single-throw (SPST) switches. The **ADG613-EP** contains two switches with digital control logic that turns on with logic low and two switches in which the logic is inverted.

Each switch conducts equally well in both directions when on and has an input signal range that extends to the supplies. The **ADG613-EP** exhibits break-before-make switching action.

Rev. 0

[Document Feedback](#)

Information furnished by Analog Devices is believed to be accurate and reliable. However, no responsibility is assumed by Analog Devices for its use, nor for any infringements of patents or other rights of third parties that may result from its use. Specifications subject to change without notice. No license is granted by implication or otherwise under any patent or patent rights of Analog Devices. Trademarks and registered trademarks are the property of their respective owners.

FUNCTIONAL BLOCK DIAGRAM

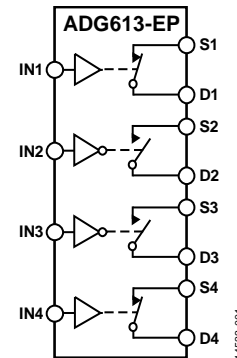

Figure 1.

The **ADG613-EP** is available in a small, 16-lead TSSOP package.

The **ADG613-EP** is also a TTL-compatible device.

Additional application and technical information can be found in the **ADG613** data sheet.

PRODUCT HIGHLIGHTS

- Ultralow charge injection (1 pC typically).
- Dual ± 2.7 V to ± 5.5 V or single 2.7 V to 5.5 V operation.
- Temperature range: -55°C to $+125^{\circ}\text{C}$.
- Small, 16-lead TSSOP.

TABLE OF CONTENTS

Features	1	Single-Supply Operation	4
Enhanced Product Features	1	Absolute Maximum Ratings	6
Applications.....	1	ESD Caution.....	6
Functional Block Diagram	1	Pin Configuration and Function Descriptions.....	7
General Description	1	Typical Performance Characteristics	8
Product Highlights	1	Test Circuits.....	10
Revision History	2	Outline Dimensions	12
Specifications.....	3	Ordering Guide	12
Dual-Supply Operation	3		

REVISION HISTORY

6/2016—Revision 0: Initial Revision

SPECIFICATIONS

DUAL-SUPPLY OPERATION

$V_{DD} = 5\text{ V} \pm 10\%$, $V_{SS} = -5\text{ V} \pm 10\%$, $GND = 0\text{ V}$, unless otherwise noted. V_S is the source voltage. V_D is the drain voltage.

Table 1.

Parameter	25°C	-55°C to +125°C	Unit	Test Conditions/Comments
ANALOG SWITCH				
Analog Signal Range		V_{SS} to V_{DD}	V	
On Resistance, R_{ON}	85		Ω typ	$V_S = \pm 3\text{ V}$, $I_S = -1\text{ mA}$; see Figure 14
	115	160	Ω max	$V_S = \pm 3\text{ V}$, $I_S = -1\text{ mA}$; see Figure 14
On-Resistance Match Between Channels, ΔR_{ON}	2		Ω typ	$V_S = \pm 3\text{ V}$, $I_S = -1\text{ mA}$
	4	6.5	Ω max	$V_S = \pm 3\text{ V}$, $I_S = -1\text{ mA}$
On-Resistance Flatness, $R_{FLAT(ON)}$	25		Ω typ	$V_S = \pm 3\text{ V}$, $I_S = -1\text{ mA}$
	40	60	Ω max	$V_S = \pm 3\text{ V}$, $I_S = -1\text{ mA}$
LEAKAGE CURRENTS				
Source Off Leakage, $I_{S(OFF)}$	± 0.01		nA typ	$V_{DD} = +5.5\text{ V}$, $V_{SS} = -5.5\text{ V}$ $V_D = \pm 4.5\text{ V}$, $V_S = \mp 4.5\text{ V}$; see Figure 15
	± 0.1	± 2	nA max	$V_D = \pm 4.5\text{ V}$, $V_S = \mp 4.5\text{ V}$; see Figure 15
Drain Off Leakage, $I_{D(OFF)}$	± 0.01		nA typ	$V_D = \pm 4.5\text{ V}$, $V_S = \mp 4.5\text{ V}$; see Figure 15
	± 0.1	± 2	nA max	$V_D = \pm 4.5\text{ V}$, $V_S = \mp 4.5\text{ V}$; see Figure 15
Channel On Leakage, $I_{D(ON)}$, $I_{S(ON)}$	± 0.01		nA typ	$V_D = V_S = \pm 4.5\text{ V}$; see Figure 16
	± 0.1	± 6	nA max	$V_D = V_S = \pm 4.5\text{ V}$; see Figure 16
DIGITAL INPUTS				
Input High Voltage, V_{INH}		2.4	V min	
Input Low Voltage, V_{INL}		0.8	V max	
Input Current, I_{INL} or I_{INH}	0.005		μA typ	$V_{IN} = V_{INL}$ or V_{INH}
		± 0.1	μA max	$V_{IN} = V_{INL}$ or V_{INH}
Digital Input Capacitance, C_{IN}	2		pF typ	
DYNAMIC CHARACTERISTICS¹				
Delay from Digital Control Input and Output Switching On, t_{ON}	45		ns typ	$R_L = 300\ \Omega$, $C_L = 35\text{ pF}$, $V_S = 3.0\text{ V}$; see Figure 17
	65	90	ns max	$R_L = 300\ \Omega$, $C_L = 35\text{ pF}$, $V_S = 3.0\text{ V}$; see Figure 17
Delay from Digital Control Input and Output Switching Off, t_{OFF}	25		ns typ	$R_L = 300\ \Omega$, $C_L = 35\text{ pF}$, $V_S = 3.0\text{ V}$; see Figure 17
	40	50	ns max	$R_L = 300\ \Omega$, $C_L = 35\text{ pF}$, $V_S = 3.0\text{ V}$; see Figure 17
Break-Before-Make Time Delay, t_{BBM}	15		ns typ	$R_L = 300\ \Omega$, $C_L = 35\text{ pF}$, $V_{S1} = V_{S2} = 3.0\text{ V}$; see Figure 18
		10	ns min	$R_L = 300\ \Omega$, $C_L = 35\text{ pF}$, $V_{S1} = V_{S2} = 3.0\text{ V}$; see Figure 18
Charge Injection	-0.5		pC typ	$V_S = 0\text{ V}$, $R_S = 0\ \Omega$, $C_L = 1\text{ nF}$; see Figure 19
Off Isolation	-65		dB typ	$R_L = 50\ \Omega$, $C_L = 5\text{ pF}$, $f = 10\text{ MHz}$; see Figure 20
Channel to Channel Crosstalk	-90		dB typ	$R_L = 50\ \Omega$, $C_L = 5\text{ pF}$, $f = 10\text{ MHz}$; see Figure 21
-3 dB Bandwidth	680		MHz typ	$R_L = 50\ \Omega$, $C_L = 5\text{ pF}$; see Figure 22
Off Switch Source Capacitance, $C_{S(OFF)}$	5		pF typ	$f = 1\text{ MHz}$
Off Switch Drain Capacitance, $C_{D(OFF)}$	5		pF typ	$f = 1\text{ MHz}$
On Switch Capacitance, $C_{D(ON)}$, $C_{S(ON)}$	5		pF typ	$f = 1\text{ MHz}$
POWER REQUIREMENTS				
Positive Supply Current, I_{DD}	0.001		μA typ	$V_{DD} = +5.5\text{ V}$, $V_{SS} = -5.5\text{ V}$ Digital inputs = 0 V or 5.5 V
		1.0	μA max	Digital inputs = 0 V or 5.5 V
Negative Supply Current, I_{SS}	0.001		μA typ	Digital inputs = 0 V or 5.5 V
		1.0	μA max	Digital inputs = 0 V or 5.5 V
V_{DD}/V_{SS}		± 2.7	V min	
		± 5.5	V max	
Power Consumption	11		nW typ	
	11		μW max	

¹ Guaranteed by design; not subject to production test.

SINGLE-SUPPLY OPERATION

$V_{DD} = 5\text{ V} \pm 10\%$, $V_{SS} = 0\text{ V}$, $GND = 0\text{ V}$, unless otherwise noted. V_S is the source voltage. V_D is the drain voltage.

Table 2.

Parameter	25°C	-55°C to +125°C	Unit	Test Conditions/Comments
ANALOG SWITCH				
Analog Signal Range		0 to V_{DD}	V	
On Resistance, R_{ON}	210		Ω typ	$V_S = 3.5\text{ V}$, $I_S = -1\text{ mA}$; see Figure 14
	290	380	Ω max	$V_S = 3.5\text{ V}$, $I_S = -1\text{ mA}$; see Figure 14
On-Resistance Match Between Channels, ΔR_{ON}	3		Ω typ	$V_S = 3.5\text{ V}$, $I_S = -1\text{ mA}$
	10	13	Ω max	$V_S = 3.5\text{ V}$, $I_S = -1\text{ mA}$
LEAKAGE CURRENTS				
Source Off Leakage, $I_{S(OFF)}$	± 0.01		nA typ	$V_{DD} = 5.5\text{ V}$ $V_S = 1\text{ V}$ or 4.5 V , $V_D = 4.5\text{ V}$ or 1 V ; see Figure 15
	± 0.1	± 2	nA max	$V_S = 1\text{ V}$ or 4.5 V , $V_D = 4.5\text{ V}$ or 1 V ; see Figure 15
Drain Off Leakage, $I_{D(OFF)}$	± 0.01		nA typ	$V_S = 1\text{ V}$ or 4.5 V , $V_D = 4.5\text{ V}$ or 1 V ; see Figure 15
	± 0.1	± 2	nA max	$V_S = 1\text{ V}$ or 4.5 V , $V_D = 4.5\text{ V}$ or 1 V ; see Figure 15
Channel On Leakage, $I_{D(ON)}$, $I_{S(ON)}$	± 0.01		nA typ	$V_S = V_D = 1\text{ V}$ or 4.5 V ; see Figure 16
	± 0.1	± 6	nA max	$V_S = V_D = 1\text{ V}$ or 4.5 V ; see Figure 16
DIGITAL INPUTS				
Input High Voltage, V_{INH}		2.4	V min	
Input Low Voltage, V_{INL}		0.8	V max	
Input Current, I_{INL} or I_{INH}	0.005		μA typ	$V_{IN} = V_{INL}$ or V_{INH}
		± 0.1	μA max	$V_{IN} = V_{INL}$ or V_{INH}
Digital Input Capacitance, C_{IN}	2		pF typ	
DYNAMIC CHARACTERISTICS¹				
t_{ON}	70		ns typ	$R_L = 300\ \Omega$, $C_L = 35\text{ pF}$, $V_S = 3.0\text{ V}$; see Figure 17
	100	150	ns max	$R_L = 300\ \Omega$, $C_L = 35\text{ pF}$, $V_S = 3.0\text{ V}$; see Figure 17
t_{OFF}	25		ns typ	$R_L = 300\ \Omega$, $C_L = 35\text{ pF}$, $V_S = 3.0\text{ V}$; see Figure 17
	40	50	ns max	$R_L = 300\ \Omega$, $C_L = 35\text{ pF}$, $V_S = 3.0\text{ V}$; see Figure 17
Break-Before-Make Time Delay, t_{BBM}	25		ns typ	$R_L = 300\ \Omega$, $C_L = 35\text{ pF}$, $V_{S1} = V_{S2} = 3.0\text{ V}$; see Figure 18
		10	ns min	$R_L = 300\ \Omega$, $C_L = 35\text{ pF}$, $V_{S1} = V_{S2} = 3.0\text{ V}$; see Figure 18
Charge Injection	1		pC typ	$V_S = 0\text{ V}$, $R_S = 0\ \Omega$, $C_L = 1\text{ nF}$; see Figure 19
Off Isolation	-62		dB typ	$R_L = 50\ \Omega$, $C_L = 5\text{ pF}$, $f = 10\text{ MHz}$; see Figure 20
Channel to Channel Crosstalk	-90		dB typ	$R_L = 50\ \Omega$, $C_L = 5\text{ pF}$, $f = 10\text{ MHz}$; see Figure 21
-3 dB Bandwidth	680		MHz typ	$R_L = 50\ \Omega$, $C_L = 5\text{ pF}$; see Figure 22
$C_{S(OFF)}$	5		pF typ	$f = 1\text{ MHz}$
$C_{D(OFF)}$	5		pF typ	$f = 1\text{ MHz}$
$C_{D(ON)}$, $C_{S(ON)}$	5		pF typ	$f = 1\text{ MHz}$
POWER REQUIREMENTS				
I_{DD}	0.001		μA typ	$V_{DD} = 5.5\text{ V}$ Digital inputs = 0 V or 5.5 V
		1.0	μA max	Digital inputs = 0 V or 5.5 V
V_{DD}		2.7	V min	
		5.5	V max	
Power Consumption	5.5		nW typ	
	5.5		μW max	

¹ Guaranteed by design; not subject to production test.

$V_{DD} = 3\text{ V} \pm 10\%$, $V_{SS} = 0\text{ V}$, $GND = 0\text{ V}$, unless otherwise noted. V_S is the source voltage. V_D is the drain voltage.

Table 3.

Parameter	25°C	-55°C to +125°C	Unit	Test Conditions/Comments
ANALOG SWITCH				
Analog Signal Range		0 to V_{DD}	V	
On Resistance, R_{ON}	380	460	Ω typ	$V_S = 1.5\text{ V}$, $I_S = -1\text{ mA}$; see Figure 14
LEAKAGE CURRENTS				
Source Off Leakage, $I_{S(OFF)}$	± 0.01		nA typ	$V_{DD} = 3.3\text{ V}$ $V_S = 1\text{ V}$ or 3 V , $V_D = 3\text{ V}$ or 1 V ; see Figure 15
	± 0.1	± 2	nA max	$V_S = 1\text{ V}$ or 3 V , $V_D = 3\text{ V}$ or 1 V ; see Figure 15
Drain Off Leakage, $I_{D(OFF)}$	± 0.01		nA typ	$V_S = 1\text{ V}$ or 3 V , $V_D = 3\text{ V}$ or 1 V ; see Figure 15
	± 0.1	± 2	nA max	$V_S = 1\text{ V}$ or 3 V , $V_D = 3\text{ V}$ or 1 V ; see Figure 15
Channel On Leakage, $I_{D(ON)}$, $I_{S(ON)}$	± 0.01		nA typ	$V_S = V_D = 1\text{ V}$ or 3 V ; see Figure 16
	± 0.1	± 6	nA max	$V_S = V_D = 1\text{ V}$ or 3 V ; see Figure 16
DIGITAL INPUTS				
Input High Voltage, V_{INH}		2.0	V min	
Input Low Voltage, V_{INL}		0.8	V max	
Input Current, I_{INL} or I_{INH}	0.005		μA typ	$V_{IN} = V_{INL}$ or V_{INH}
		± 0.1	μA max	$V_{IN} = V_{INL}$ or V_{INH}
Digital Input Capacitance, C_{IN}	2		pF typ	
DYNAMIC CHARACTERISTICS¹				
t_{ON}	130		ns typ	$R_L = 300\ \Omega$, $C_L = 35\text{ pF}$, $V_S = 2\text{ V}$; see Figure 17
	185	260	ns max	$R_L = 300\ \Omega$, $C_L = 35\text{ pF}$, $V_S = 2\text{ V}$; see Figure 17
t_{OFF}	40		ns typ	$R_L = 300\ \Omega$, $C_L = 35\text{ pF}$, $V_S = 2\text{ V}$; see Figure 17
	55	65	ns max	$R_L = 300\ \Omega$, $C_L = 35\text{ pF}$, $V_S = 2\text{ V}$; see Figure 17
Break-Before-Make Time Delay, t_{BBM}	50		ns typ	$R_L = 300\ \Omega$, $C_L = 35\text{ pF}$, $V_{S1} = V_{S2} = 2\text{ V}$; see Figure 18
		10	ns min	$R_L = 300\ \Omega$, $C_L = 35\text{ pF}$, $V_{S1} = V_{S2} = 2\text{ V}$; see Figure 18
Charge Injection	1.5		pC typ	$V_S = 0\text{ V}$, $R_S = 0\ \Omega$, $C_L = 1\text{ nF}$; see Figure 19
Off Isolation	-62		dB typ	$R_L = 50\ \Omega$, $C_L = 5\text{ pF}$, $f = 10\text{ MHz}$; see Figure 20
Channel to Channel Crosstalk	-90		dB typ	$R_L = 50\ \Omega$, $C_L = 5\text{ pF}$, $f = 10\text{ MHz}$; see Figure 21
-3 dB Bandwidth	680		MHz typ	$R_L = 50\ \Omega$, $C_L = 5\text{ pF}$; see Figure 22
$C_{S(OFF)}$	5		pF typ	$f = 1\text{ MHz}$
$C_{D(OFF)}$	5		pF typ	$f = 1\text{ MHz}$
$C_{D(ON)}$, $C_{S(ON)}$	5		pF typ	$f = 1\text{ MHz}$
POWER REQUIREMENTS				
I_{DD}	0.001		μA typ	$V_{DD} = 3.3\text{ V}$
		1.0	μA max	Digital inputs = 0 V or 3.3 V
V_{DD}		2.7	V min	Digital inputs = 0 V or 3.3 V
		5.5	V max	
Power Consumption	3.3		nW typ	
	3.3		μW max	

¹ Guaranteed by design; not subject to production test.

ABSOLUTE MAXIMUM RATINGS

$T_A = 25^\circ\text{C}$, unless otherwise noted

Table 4.

Parameter	Rating
V_{DD} to V_{SS} ¹	13 V
V_{DD} to GND ¹	-0.3 V to +6.5 V
V_{SS} to GND ¹	+0.3 V to -6.5 V
Analog Inputs ²	$V_{SS} - 0.3\text{ V}$ to $V_{DD} + 0.3\text{ V}$
Digital Inputs ²	GND - 0.3 V to $V_{DD} + 0.3\text{ V}$ or 30 mA, whichever occurs first
Peak Current, Sx or Dx	20 mA (pulsed at 1 ms, 10% duty cycle maximum)
Continuous Current, Sx or Dx	10 mA
3 V Operation, 85°C to 125°C	7.5 mA
Operating Temperature Range	-55°C to +125°C
Storage Temperature Range	-65°C to +150°C
Junction Temperature	150°C
θ_{JA} Thermal Impedance	
16-Lead TSSOP	150.4°C/W
Lead Soldering	
Lead Temperature, Soldering (10 sec)	300°C
IR Reflow, Peak Temperature (<20 sec)	220°C
Pb-Free Soldering	
Reflow, Peak Temperature	260 (+0/-5)°C
Time at Peak Temperature	20 sec to 40 sec

¹ Tested at -55°C to +125°C.

² Overvoltages at INx, Sx, or Dx are clamped by internal diodes. Limit the current to the maximum ratings given. Tested at -55°C to +125°C.

Stresses at or above those listed under Absolute Maximum Ratings may cause permanent damage to the product. This is a stress rating only; functional operation of the product at these or any other conditions above those indicated in the operational section of this specification is not implied. Operation beyond the maximum operating conditions for extended periods may affect product reliability.

Only one absolute maximum rating can be applied at any one time.

ESD CAUTION



ESD (electrostatic discharge) sensitive device.

Charged devices and circuit boards can discharge without detection. Although this product features patented or proprietary protection circuitry, damage may occur on devices subjected to high energy ESD. Therefore, proper ESD precautions should be taken to avoid performance degradation or loss of functionality.

PIN CONFIGURATION AND FUNCTION DESCRIPTIONS

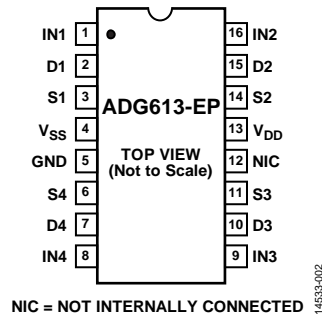

Figure 2. Pin Configuration

Table 5. Pin Function Descriptions

Pin No.	Mnemonic	Description
1	IN1	Switch 1 Digital Control Input.
2	D1	Drain Terminal of Switch 1. This pin can be an input or output.
3	S1	Source Terminal of Switch 1. This pin can be an input or output.
4	V _{SS}	Most Negative Power Supply Terminal. Tie this pin to GND when using the device with single-supply voltages.
5	GND	Ground (0 V) Reference.
6	S4	Source Terminal of Switch 4. This pin can be an input or output.
7	D4	Drain Terminal of Switch 4. This pin can be an input or output.
8	IN4	Switch 4 Digital Control Input.
9	IN3	Switch 3 Digital Control Input.
10	D3	Drain Terminal of Switch 3. This pin can be an input or output.
11	S3	Source Terminal of Switch 3. This pin can be an input or output.
12	NIC	Not Internally Connected.
13	V _{DD}	Most Positive Power Supply Terminal.
14	S2	Source Terminal of Switch 2. This pin can be an input or output.
15	D2	Drain Terminal of Switch 2. This pin can be an input or output.
16	IN2	Switch 2 Digital Control Input.

Table 6. Truth Table

Logic	S1 and S4	S2 and S3
0	Off	On
1	On	Off

TYPICAL PERFORMANCE CHARACTERISTICS

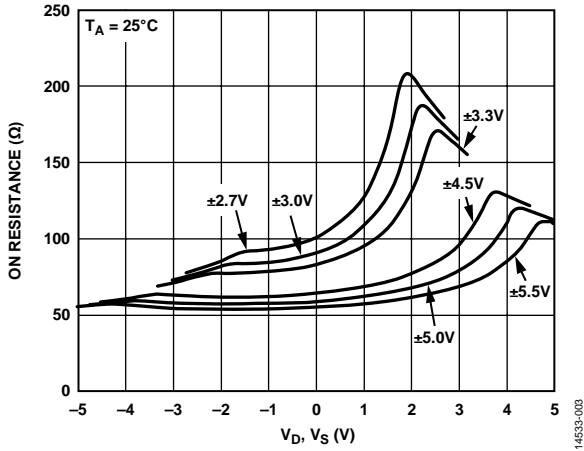

Figure 3. On Resistance vs. V_D , V_S ; Dual Supplies

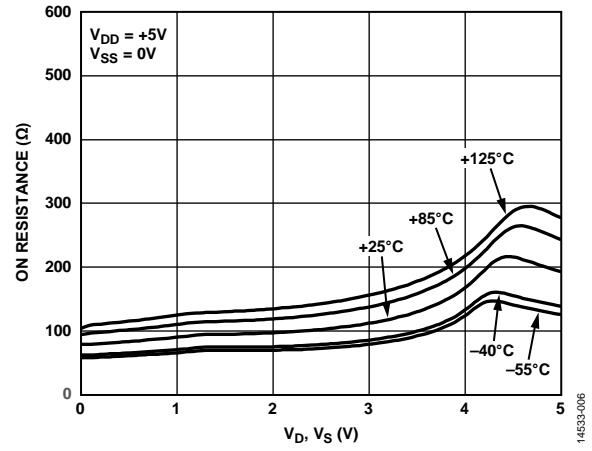

Figure 6. On Resistance vs. V_D , V_S for Various Temperatures, Single Supply

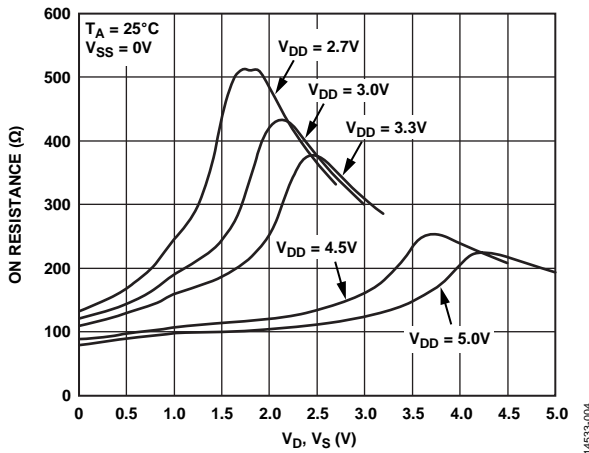

Figure 4. On Resistance vs. V_D , V_S ; Single Supply

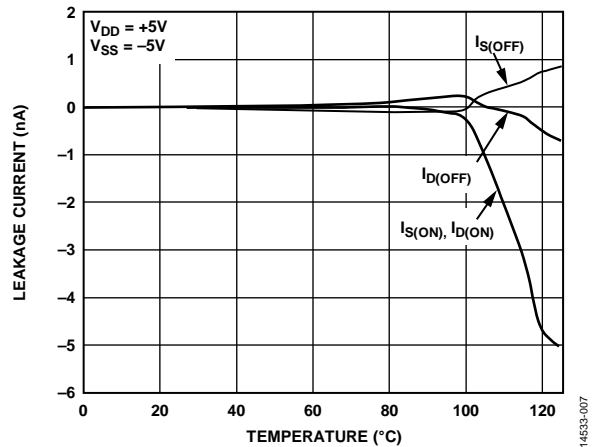

Figure 7. Leakage Current vs. Temperature, Dual Supplies

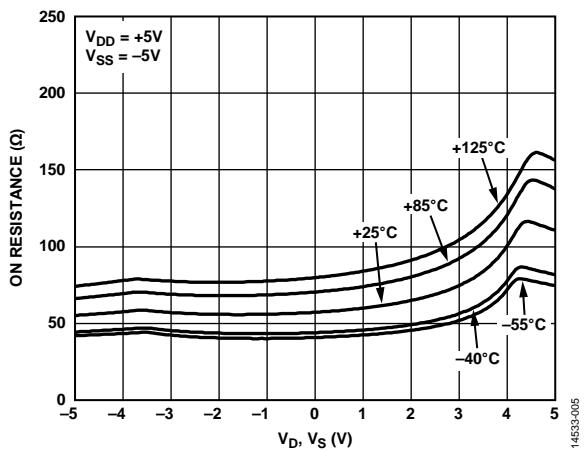

Figure 5. On Resistance vs. V_D , V_S for Various Temperatures, Dual Supplies

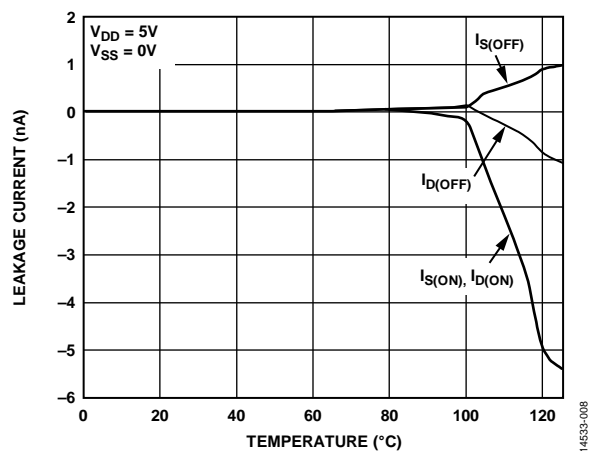

Figure 8. Leakage Current vs. Temperature, Single Supply

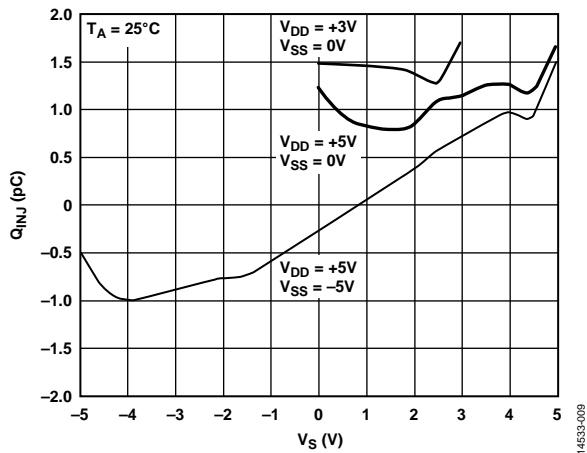

Figure 9. Charge Injection (Q_{INJ}) vs. Source Voltage (V_S)

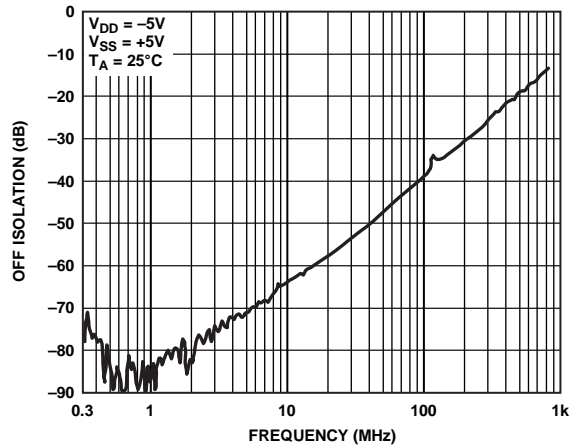

Figure 12. Off Isolation vs. Frequency

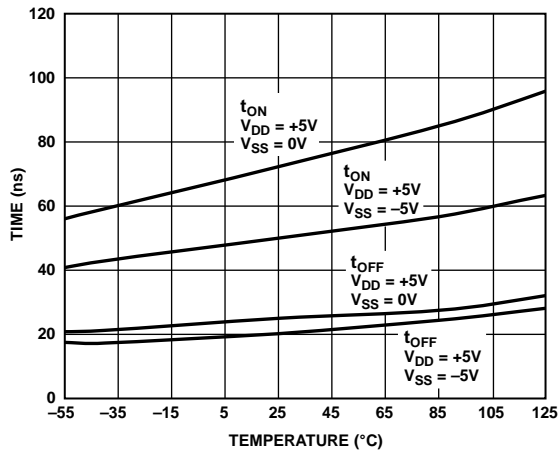

Figure 10. t_{ON}/t_{OFF} Times vs. Temperature

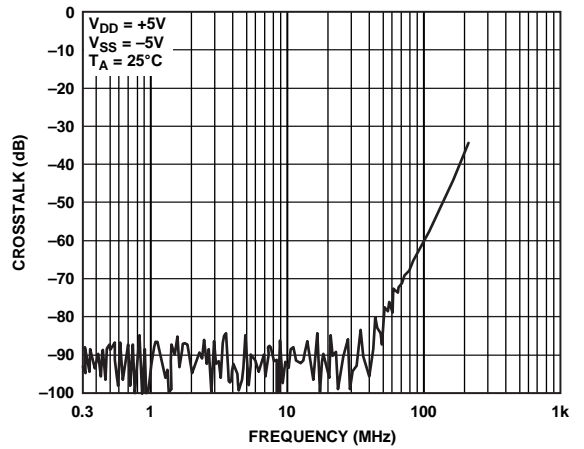

Figure 13. Crosstalk vs. Frequency

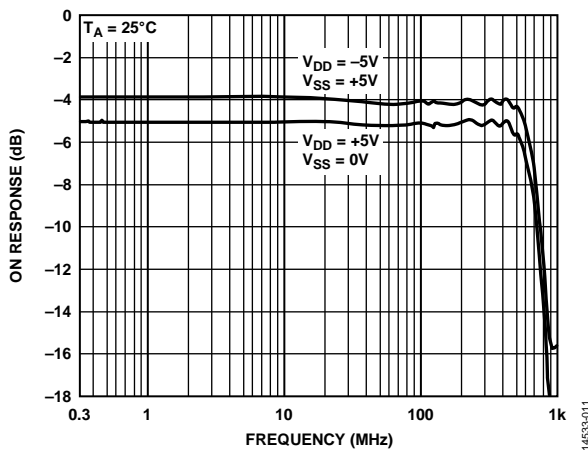

Figure 11. On Response vs. Frequency

TEST CIRCUITS

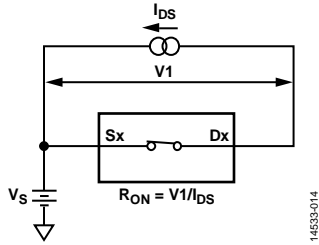

Figure 14. On Resistance

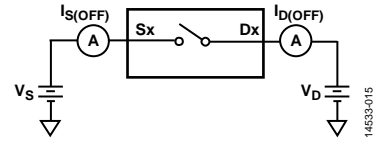

Figure 15. Off Leakage

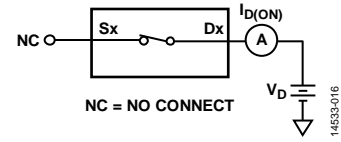

Figure 16. On Leakage

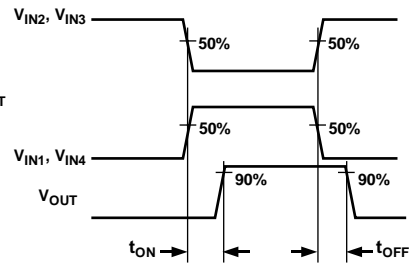
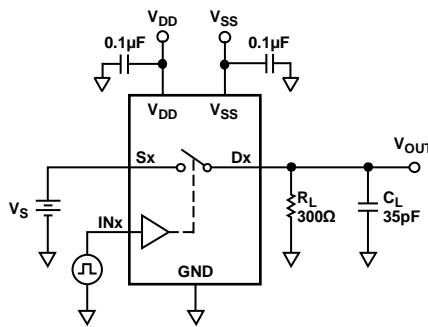

Figure 17. Switching Times

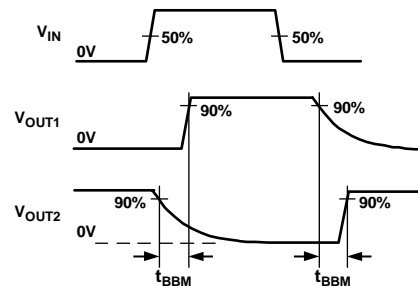
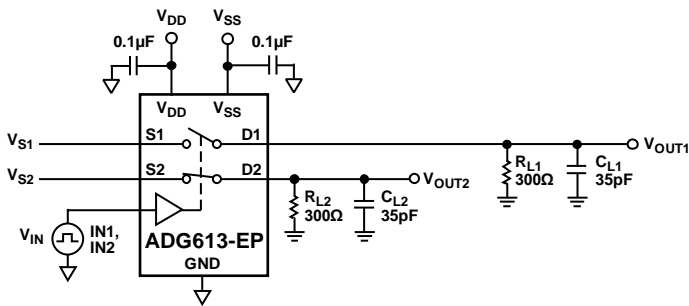

Figure 18. Break-Before-Make Time Delay

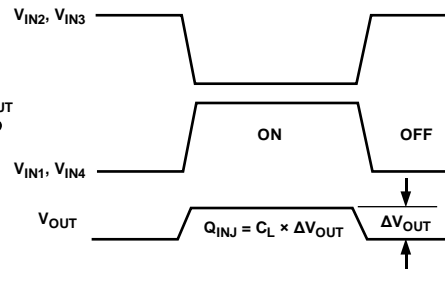
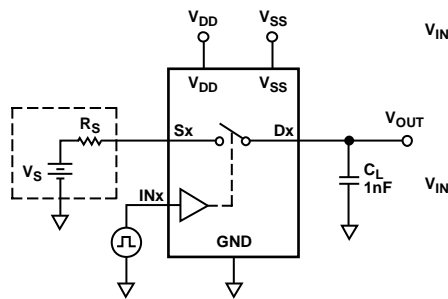

Figure 19. Charge Injection

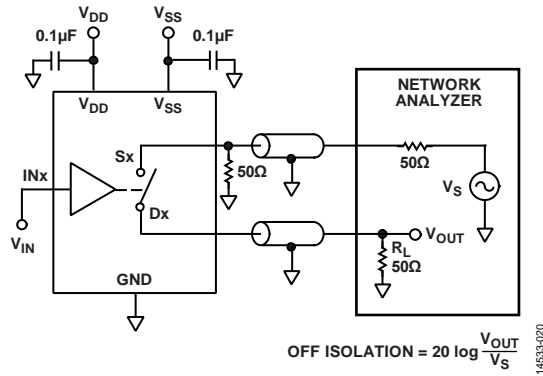

Figure 20. Off Isolation

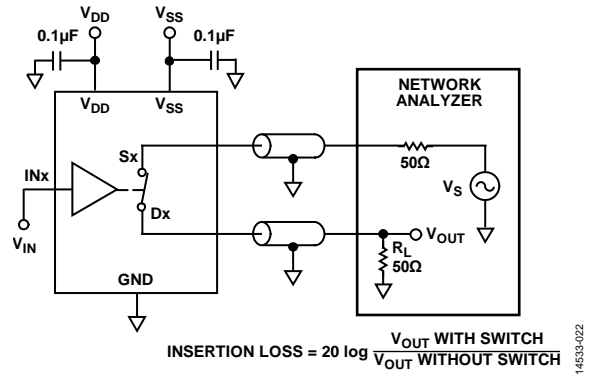

Figure 22. Bandwidth

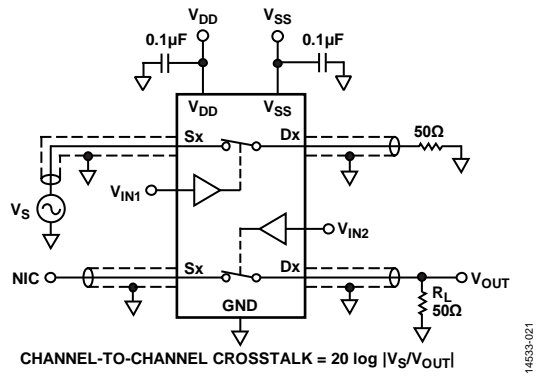
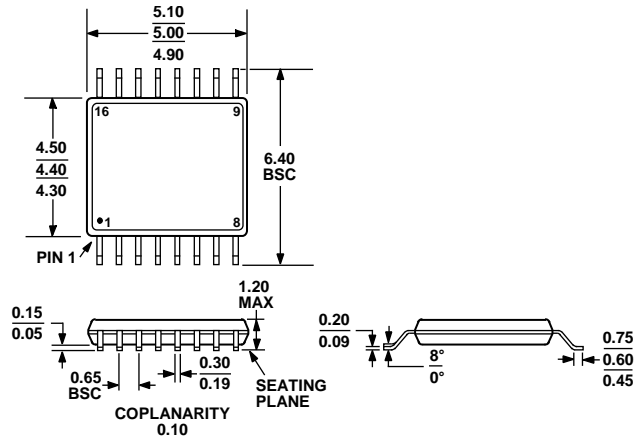

Figure 21. Channel-to-Channel Crosstalk

OUTLINE DIMENSIONS



COMPLIANT TO JEDEC STANDARDS MO-153-AB

Figure 23. 16-Lead Thin Shrink Small Outline Package [TSSOP] (RU-16)

Dimensions shown in millimeters

ORDERING GUIDE

Model ¹	Temperature Range	Package Description	Package Option
ADG613SRUZ-EP	-55°C to +125°C	16-Lead Thin Shrink Small Outline Package [TSSOP]	RU-16
ADG613SRUZ-EP-RL7	-55°C to +125°C	16-Lead Thin Shrink Small Outline Package [TSSOP]	RU-16

¹ Z = RoHS Compliant Part.

Mouser Electronics

Authorized Distributor

Click to View Pricing, Inventory, Delivery & Lifecycle Information:

[Analog Devices Inc.:](#)

[ADG613YRUZ-REEL7](#) [ADG613YRUZ](#) [ADG613SRUZ-EP-RL7](#) [ADG613SRUZ-EP](#)